



ST. ALOYSIUS' COLLEGE

**AUTONOMOUS
JABALPUR- 482001
MADHYA PRADESH, INDIA**

CRITERION-1



CURRICULAR ASPECTS

Key Indicator – 1.3

Curriculum Enrichment

Metric No.: 1.3.3

**Percentage of programmes that have components of
Field projects / Research projects / Internships during
the last five years.**

Document Name

**Sample Evaluated Project report/Field work
Report submitted by the students
2019-20**



ST. ALOYSIUS' COLLEGE

(AUTONOMOUS), JABALPUR(M.P.)

Reaccredited 'A+' Grade by NAAC (CGPA 3.68/4.00)

College with Potential for Excellence (CPE) by UGC

DST-FIST Supported & Star College Scheme by DBT.

SAMPLE PROJECT REPORTS

2019-20

FACULTY OF ARTS

ST. ALOYSIUS COLLEGE (AUTONOMOUS)



St. Aloysius' College
(Autonomous) Jabalpur

Re Accredited 'A' grade by NAAC

2019-20

PROJECT REPORT ON OLD SCHOOLS OF JABALPUR

Dr. Manju Maria Solomon
Dr. Manju Maria Solomon

Head

Dept. of History

St. Aloysius College (Auto.)

Jabalpur (M. P.)

Gauri Porwal
Gauri Porwal

UNDER THE GUIDANCE OF

DR. MANJU M. SOLOMON

SUBMITTED BY

GAURI PORWAL

CERTIFICATE OF THE SURVEYED INSTITUTION

THIS IS TO CERTIFY GAURI PORWAL OF B.A VITH
SEMESTER HAS VISITED OLD SCHOOLS FOR HER PROJECT
WORK ON STUDY OF OLD SCHOOLS AND HER BEHAVIOUR
WAS SATISFACTORY.

DATE.....04/09/19

PLACE : JABALPUR

SIGNATURE :

NAME : FR. SIBI JOSEPH

DESIGNATION : PRINCIPAL

OFFICE / INSTITUTION

Principal
St. Aloysius Sr. Sec. School
Jabalpur - 482 001



ACKNOWLEDGEMENT ...

→ The success and final outcome of this project required a lot of guidance, supervision, assistance and hard work from many people and I am extremely privileged to have got this all along the completion of my project. All that I have done is only due to such support and cooperation and I would not forget to thank and praise them.

I respect and thank our History Professor DR. (Mrs.) MANJU MARIA SOLOMON mam for providing me an opportunity to do the project work on OLD SCHOOLS OF JABALPUR and giving me all support which made me complete the project duty, I owe my deep gratitude to her who not only guided me all along, but also shared her knowledge with me, last but not the least I am thoroughly thankful to not only get constant support but fortunate enough to get supplying and guidance from my family, friends and classmates.

GAURI PORWAL
BA VIth Sem

INDEX

S.NO	TOPIC	PAGE No.
1.	PROFORMA	1-5
2.	ST. ALOYSIUS SCHOOL	6-25
	2.1 INTRODUCTION (SAINT PATRON)	
	2.2 ABOUT SCHOOL	
	2.3 BRIEF HISTORY	
	2.4 ADMINISTRATION	
	2.5 VISION, MISSION	
	2.6 AIMS & OBJECTIVES	
	2.7 EVENTS	
	2.8 MEANING OF SCHOOL EMBLEM	
3.	ST. JOSEPH CONVENT GIRL'S SCHOOL	26-40
	3.1 INTRODUCTION (SAINT PATRON)	
	3.2 ABOUT SCHOOL	
	3.3 BRIEF HISTORY	
	3.4 VISION	
	3.5 AIMS & OBJECTIVES	
	3.6 EVENTS	
	3.7 MEANING OF SCHOOL EMBLEM	
	3.8 ADMINISTRATION	

4.	CHRIST CHURCH BOYS' SCHOOL	41 - 60
	4.1 INTRODUCTION (FOUNDATION)	
	4.2 ABOUT SCHOOL	
	4.3 BRIEF HISTORY	
	4.4 OBJECTIVES	
	4.5 GOALS	
	4.6 ACADEMICS	
	4.7 EVENTS	
	4.8 CELEBRATIONS	
5.	CONCLUSION	61
6.	BIBLIOGRAPHY	62

PROFORMA

ST. ALOYSIUS SCHOOL



Ques 1. TITLE OF THE PROJECT ?

→ " OLD SCHOOLS IN JABALPUR "

Ques 2. OBJECTIVE OF THE PROJECT ?

→ The main objective of the project is to explore the hundred of years old schools of Jabalpur city and enquire a deep study of their historical significance, like about their foundation and founders, enquiring about the changes in their education system with the changing years and how they are still providing excellence in their field since establishment.

Ques 3. EMPLOYABILITY ?

→ The project has been made under the supervision of Dr. Manju Mania Solomon, with the basic intention of providing employment opportunity to the history graduates as it has helped me to enhance my skills, preparedness and capacity to meet the upcoming challenges for employment.

It has also encouraged my willingness to perform my best at the work intended.

On the other hand, I would brush up our personality as a future employee. As it would intend me as a person to work hard in order to achieve success.

Ques 4. DESCRIPTION OF THE INSTITUTION VISITED FOR STUDY!
(Day and date Details)

→

DATE	DAY	DESCRIPTION
11.03.19	Monday	ST. ALOYSIUS Sr. Sec. SCHOOL.
11.03.19	Monday	ST. JOSEPH CONVENT GIRLS' SR. SEC. SCHOOL.
12.03.19	Tuesday	CHRIST CHURCH BOYS' SR. SEC. SCHOOL.

5. BY STUDENTS OBJECTIVE RELATED KNOWLEDGE AND ITS COLLECTION, EFFORTS? (REFERENCES)

My visit to the three glorified schools, in Jabalpur city, enabled me to get various information about the schools, right

ST. JOSEPH CONVENT GIRLS' SCHOOL



forth when, why, where and by whom the schools came into existence.

I was amazed how graciously the institutions have kept their traditions from so many years and are still sewing the institutes motives so well! I got to know about them keeping their traditions alive till now. I was overwhelmed with their hospitality and their co-operation by sharing all the knowledge, I was very much impressed by their dedication towards the country and with their motive of sewing OUR COUNTRY, by forming the personalities of childrens'.

→ The following websites were very helpful during the survey :

- * <https://ccbs.s.s.org>.
- * <https://en.m.wikipedia.org>.
- * <https://staloy.sivs.jabalpur.edu.in>.
- * sjcsadar.org.

Even the annual school magazines, diary or prospectus has been helpful companion a treasure trove for gathering extra information.

Ques 6. CHALLENGES AND POSSIBILITIES FOR FUTURE OBJECTIVE ?

→

The current challenge is to revive the dying spirit of youth in India and enlighten them about our historically rich heritage and share the significance of such institutions, who had been sewing the country since past hundreds of years.

People need to encounter the significance and their contribution in the society. The possibilities may be that the more people get aware of such historically significant places, the more efforts and initiatives would be taken by the school authorities in order to preserve such part from deteriorating.

57. WHAT IS THE DIFFERENCE BETWEEN PRACTICAL AND THEORETICAL KNOWLEDGE ?

Knowledge can be defined as familiarity with something, which can be included some facts, information about a particular topic or subject, descriptions of experiment or study, or skills acquired through experience or education. Knowledge can be of two types :-

CHRIST CHURCH BOYS' SCHOOL

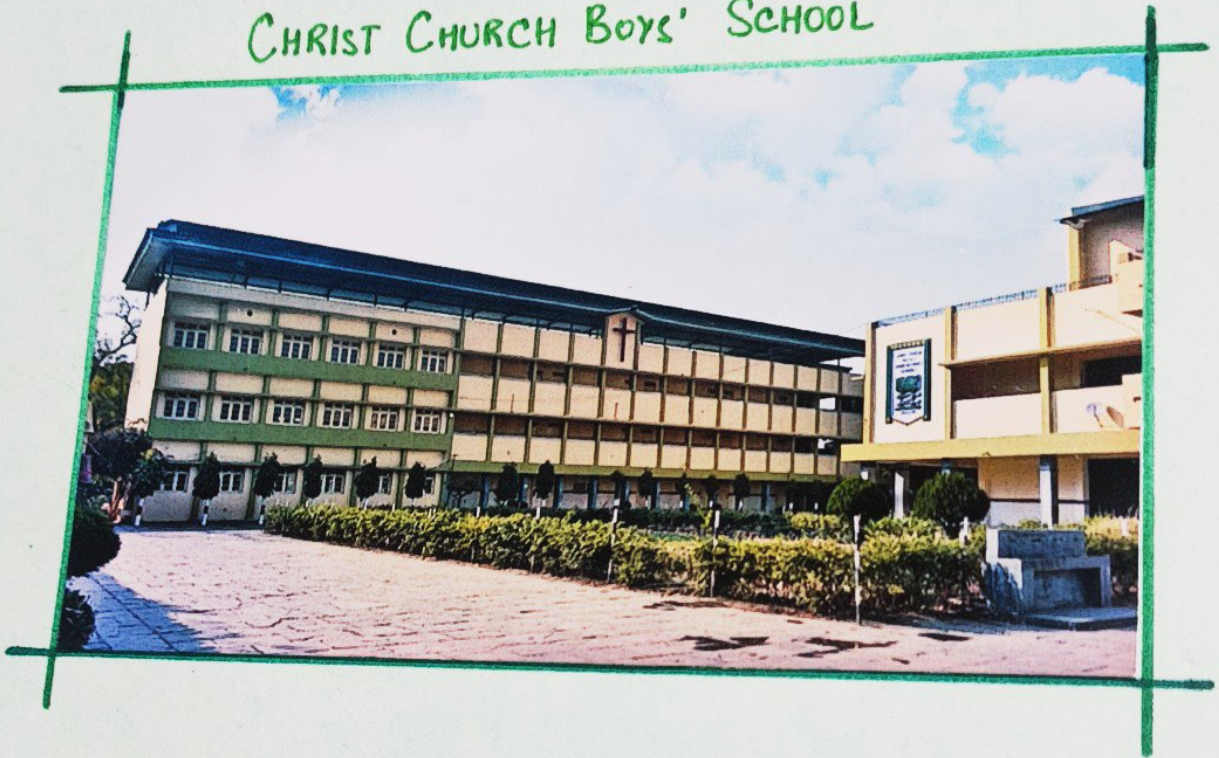

- Theoretical knowledge.
- Practical knowledge.

→ Theoretical knowledge is as important as the practical one. Without having a proper theoretical knowledge, practical knowledge may sometimes prove to be dangerous. As they say, that a little knowledge is a dangerous thing.

Theory generally teaches us 'why'. It helps you understand why one technique works while the other fails.

→ Practical knowledge manifests itself as skills or 'knowing-how'. Practical knowledge is very important to understand how things actually work. As it occurs and develops in the concrete situations where it is learnt. Practical knowledge is found to be of much use in our actual day to day work. Where theory is often taught in the idea of vacuum the practical is learned through the reality of life.

ST. ALOYSIUS SR. SEC
SCHOOL

JABALPUR (MP)

1868



Saint Aloysius



INTRODUCTION

ABOUT PATRON SAINT

→ Aloysius Gonzaga was the eldest son of Marquis Ferdinand of Gonzaga, Duke of Montara, Prince of the Holy Roman Empire, he was born in the year 1568. He was brought up piously by his mother. At the age of 10, Aloysius began to impose on himself a pitiless discipline and severe fasts in order to conquer his quick temper and ready criticism of atheists. At the age of 12, he received his first Holy communion from St. Charles Borromeo, the Archbishop of Milan.

Young Aloysius resigned his title in favour of his brother and decided to become a religious priest. But his father vehemently opposed his son's plans. Aloysius was even sent to the court of Phillip II of Spain to have his mind diverted from becoming a religious. At the age of 17, with the consent of his father and total support of his devout mother, Aloysius joined the order of the society of JESUS in Rome. Aloysius had developed his prayer life and was obedient to his superiors from the very beginning. This conformity to the will of God produced in him marvellous peace of mind. He worked very hard at his studies

As a student he wrote "I am a twisted piece of iron and have entered religion in order to get straightened out". While working hard at his studies, Aloysius found time to help those in need. A great famine broke out in Italy in the year 1590, followed by plague.

Aloysius was just 22 years of age and yet he volunteered to solicit alms and nurse the sick. The following year in March 1591, Aloysius too fell ill and after patiently suffering for 3 months he died in June, 1591. Aloysius was only 23 when he died. The church declared him as the special protector and patron of youth especially students. He is also invoked against problems of eyes and plague. His was an exemplary life. With St. Aloysius we should be able to say; "I will sing forever the mercies of the Lord".

EXTERIOR BUILDING

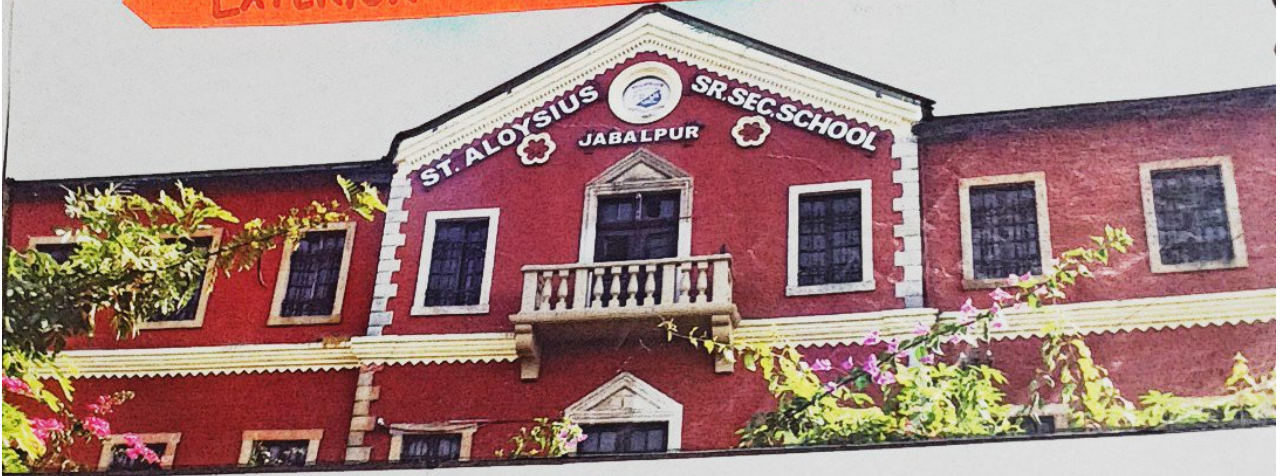

INTERIOR BUILDING

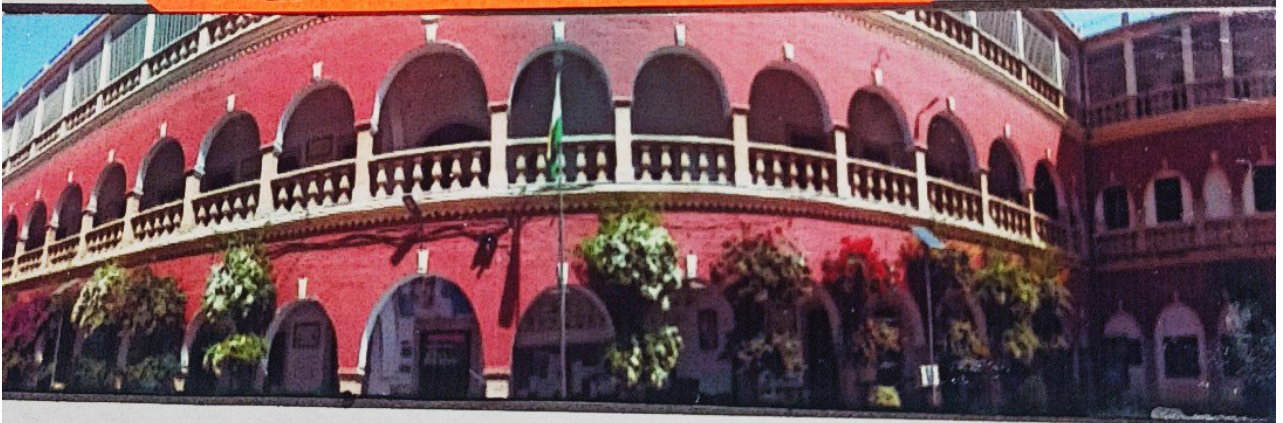

ST. ALOYSIUS' COLLEGE
PRINCIPAL
Jabalpur

ABOUT SCHOOL

→ St. Aloysius Sr. Sec. School, one of the premier institutions, in the state is owned and established by the Catholic Diocese of Jabalpur, and it is administered by the Diocese through the Jabalpur Diocesan Educational Society, a registered body under the society of registration Act M.P. in 1968.

St. Aloysius school had its humble beginning in the year 1869, when Fr. Montaigneux Delalex MSFS from Nagpur came and started the school with six orphan children. In the year 1873, the primary school was recognised by the govt. and the middle school get recognition in the year 1884.

The school is a co-ed convent school located in the city of Jabalpur, Madhya Pradesh, India. It is affiliated to Central Board of Secondary Education. It is one of the oldest school in India.

WALL WITH HISTORY OF THE BUILDING



Architecture of the Building, represents the remarkable

construction of the school Building.

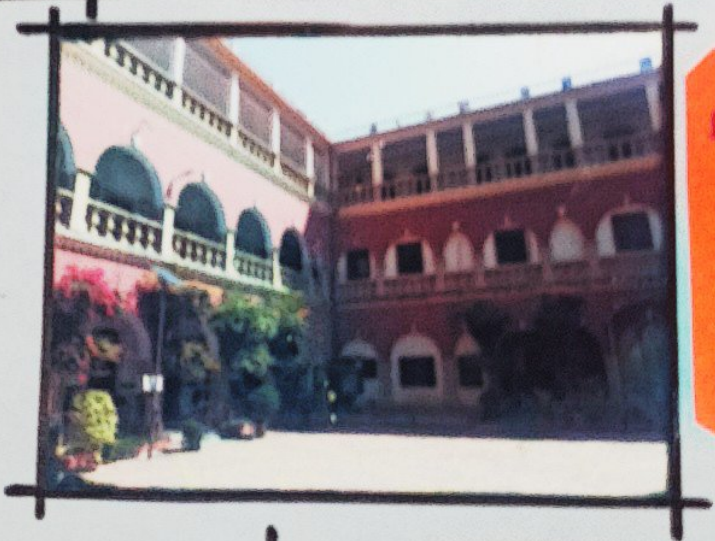

Building is well cleaned

Maintained & Stunning.

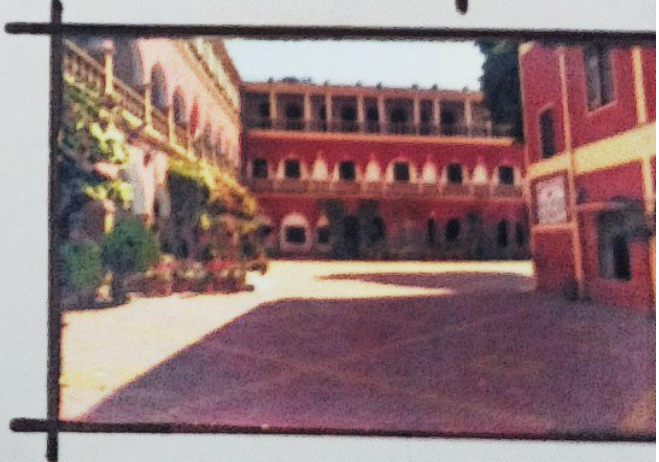

PICTURES FROM VISITING SITE



Students were very polite &

welcoming in nature

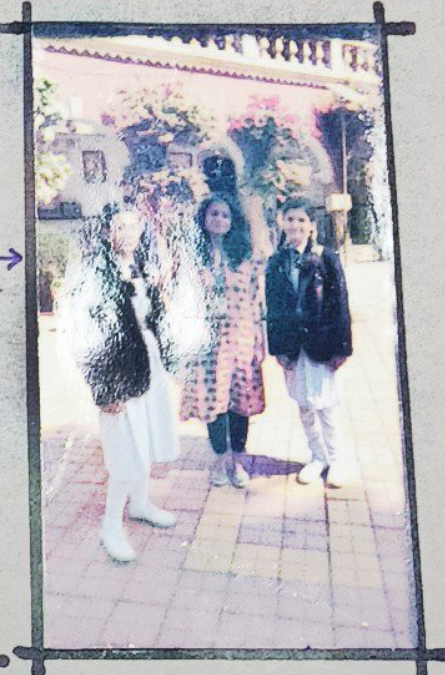



THE TEAM OF DREAMERS & BUILDERS

- First Row :** Mr. Sumeet David, Mr. Sumit Sawlapurkar, Mr. E.D. Ashish, Mr. Cherian Varghese, Mr. Sakya Nadan Joseph, Mr. Sunil Singh, Mr. Fedric David, Dr. Manish Dubey, Mrs. Deepthi Satsangi.
- Second Row :** Mrs. Manddeep, Mrs. Sweety Lawrence, Mrs. Shanti Pinto, Mrs. Monica Pachori, Mrs. Sumita Singh, Mrs. Sangeeta Bhatt, Mrs. Purнима Francis, Mrs. Ekta Panday, Ms. Shilpa Bhatha, Mrs. Manju Rangji, Ms. Trisha Batta, Mrs. Harshita Chandran, Ms. Sunita Baghel, Mrs. Anshu Pathak, Ms. Sukriti Mishra, Mrs. Anny Parekh, Mrs. Anupama Daniel.
- Third Row :** Mrs. Rupali Pillai, Mrs. Jessy Philip, Mrs. Varunu Bernard, Mrs. Vandana Tuli, Mrs. Jini Ashish, Mrs. Bhavna Tripathi, Mrs. Ritu Bhargava, Mrs. Inderjeet K. Kapoor, Mrs. Veena Rai, Ms. Disha Arora, Mrs. Geetanjali Kundu, Mrs. Tabassum Sheikh Patel, Ms. Dilpreet Kaur Bhatia.
- Fourth Row :** Mrs. Mubarak Fatima, Mrs. Swati Chakraborty, Mrs. Geeta Iswani, Mrs. Celestina Bannay, Mrs. Reena Vijjain, Mrs. Priya Kapadia, Mrs. Shivangi Sahu, Mrs. Pooja Sisodiya, Mrs. Raveen Chaddha, Mrs. Renu Singh, Ms. Palak Mahajan, Mrs. Arpita Philip, Mrs. Shweta Khare, Mrs. Rojoa Chaddha, Mrs. Suman Kohli, Mrs. Kiran Malviya.
- Fifth Row :** Mrs. Rhonda Jones, Mrs. Anita D'mello, Mrs. Susan Almeida, Mrs. Pushpa Pawar, Mr. Shagrad Singh, Mrs. Joyce Pereira, Rev. Fr. Sibi Joseph, Sr. Alphonsa A.P, Mr. A. M. Namdeo, Mr. Rajesh Vishwakarma, Mrs. Philo Aunto, Mrs. Leena J. Jacob, Mrs. Carmen Michael.

OTHER IMAGES SCHOOL PREMISES

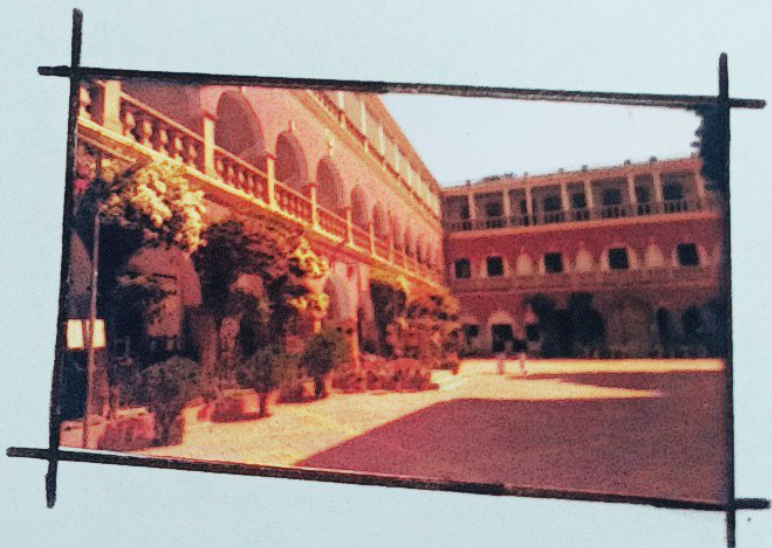
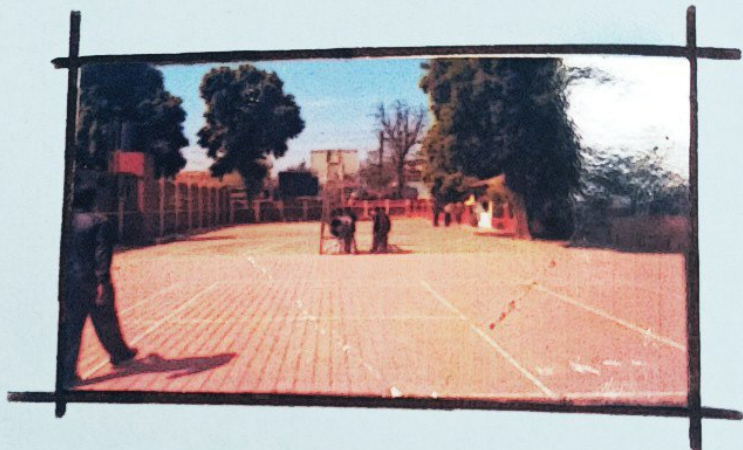
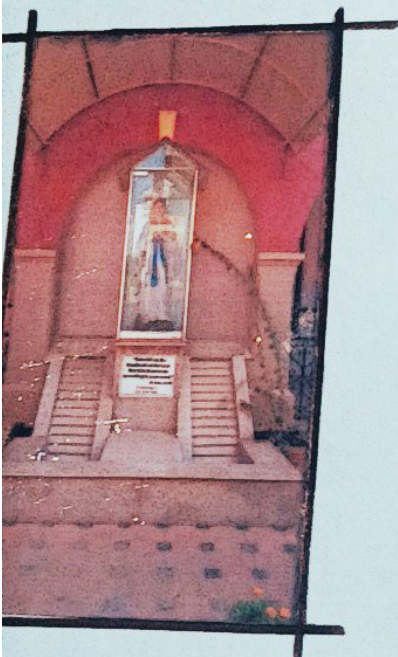
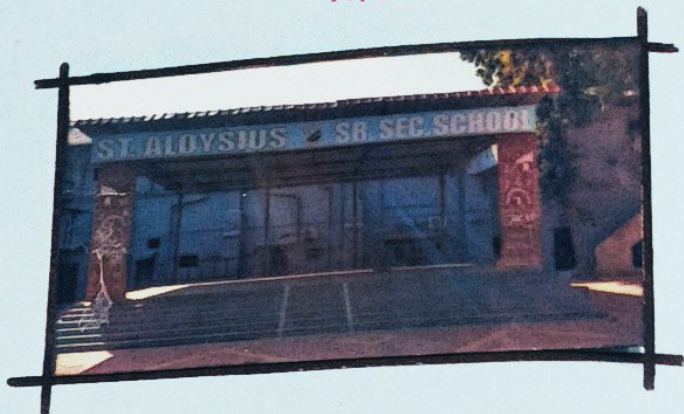

St. Aloysius School in the year was following the Cambridge syllabus for quite some time and it switched over to the M.P. Board and became a Higher Secondary school in the year 1965.

The school got affiliated to the central Board of secondary Education in the year 1994, during the tenure of Fr. Charles Menezes as principal. Fr. George P.A. took over as Principal with Fr. Thankachan Jose as vice principal on 12th Nov 1997. In 1998, the school switched over to a co-ed school, and in the same year an additional section was added to the school due to the increasing demand for more admissions. (In 1999 Fr. Mathew Joseph joined the Aloysian Family as Vice Principal) Fr. Thankachan Jose was the Principal from 19th June 2008 to April 2016. Fr. Sibi Joseph took over as the principal from May 2016.

India gained independence from the British in 1947 and the European boarding section was shut down in 1949 which later became a part of the present St. Aloysius College. Smart Class were introduced in 2008. Computer Education was started in the year 1987 from Class III onwards.

“ ADMINISTRATIVE STAFF ”



ADMINISTRATION

→ The Jabalpur Diocesan Educational Society runs schools, colleges, hospitals, cathedrals and boardings. It also conducts non-formal education and medical camps both in urban and rural areas. The Catholic Bishop of the diocese of Jabalpur is the president of the society. The growing need to educate the people in rural and urban areas prompted the Bishop of Jabalpur to establish a registered society in the diocese of Jabalpur. The Jabal Diocesan Educational Society came into existence on 3 May 1968.

The society has more than 30 schools and boardings in the urban and rural areas of Jabalpur, Shajdel, Sagar, Anuppur, Umaria, Seoni, Katni, Mandla and Dindori districts. Apart from the schools and boardings, it conducts non-formal education classes and also conducts social service activities like medical camps, social awareness programmes etc. in the rural areas. The society also administers several cathedrals, the St. Aloysius schools of Palipathar and Rimjha, the St. Thomas school, St. Aloysius Institute of Technology, St. Aloysius College, all situated in Jabalpur.

VISION OF EXCELLENCE



MISSION OF MAINTAINING



SCHOOLS' ESTEEM

VISION

→ The work continuously in a holistic and harmonious environment towards providing and establishing excellence in quality education.

MISSION

→ The school recognizes that each student is a unique creation of God, who are cared and fostered by a compassionate team of educators empowered to promote the value of learning to imbibe the value of self-worth among students, to provide quality education in a safe and supportive environment that promotes self-discipline, motivation & excellence in learning and transforming students into independent adults who will contribute responsibly in the global community.

“ AIM OF SERVING AND TEACHING ”



AIMS & OBJECTIVE

→ The aim of this educational institution is this integral formation of the child who grows and becomes aware of the world and its people, its diverse cultures and problems, and prepares himself/herself to function in his/her chosen career with a quality in his/her relationship with his/her creator and with those he/she comes into contact, thus finding that fulfilment which comes from the ultimate goal of doing everything for the glory of God and the good of one's neighbour.

It endeavours to give an all-round education, liberal, technical, physical, moral and spiritual, primarily to Catholics for whose education the school is established and to the extent possible, to children of all other communities.

The institution enjoys the right to manage administer and carry on any concern of whatever nature, conducive to the material moral, educational and physical welfare of the students.



TAKING THEIR LEGACY AHEAD

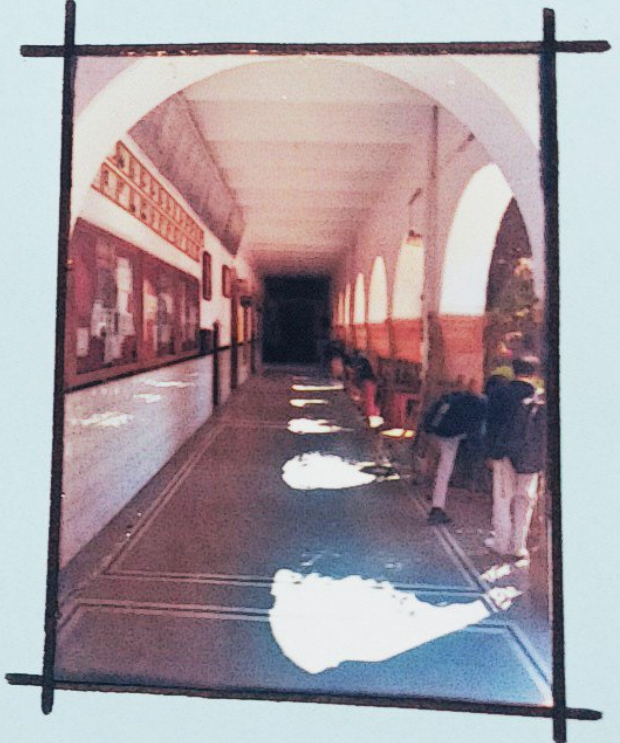
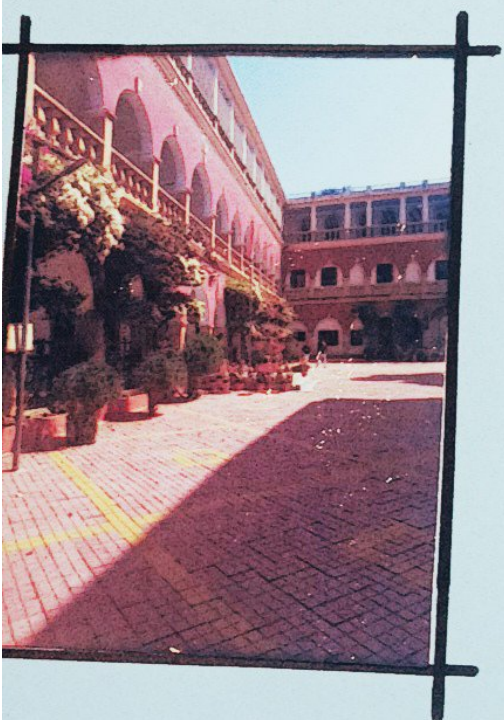

To achieve this, the Principal, staff and students draw their inspiration from Jesus Christ who lived and died for the salvation and development of every human being.

TAKING LEGACY AHEAD

→ "Every good and perfect gift is from above, coming down from the father of the heavenly lights."

The secret of change is to focus all your energy on building the new. Successful leadership is all about unlocking people's potential to become better, Rev. Fr. Sibi Joseph initiated ISIP, where the staff members who have expertise in a subject take on the role of a trainer and conduct teacher's training, internally, improving both the staff and the organisation effectiveness. This year the staff benefitted with a workshop conducted by the deans of various subjects fulfilling the aim "Together We Grow". We pray that God will continue to use our principal to lead the students and teachers to greater heights and take the legacy of the school ahead.

"Be strong and courageous, for the Lord your God is with you wherever you go."



FOUNDERS' DAY CELEBRATION



EVENTS

FOUNDERS' DAY

→ Great Journeys start off with small steps', so did the journey of St. Aloysius Sr. Sec. School. It began with our founder Fr. Amedee Delalex MSFS in 1862 with six orphan boys. It was Fr. Amedee Delalex whose vision and resources helped in laying the foundation of this great school. The Aloysian fraternity observed founders Day with a grand celebration. A show programme was put up by the students as a mark of respect to the founder. The highlight of the programme was a short movie based on how the school reached height under the guidance of various Principals. The programme ended with enlightening words spoken by the Rev. Fr. Juv D' Souza and the principal Rev. Fr. Sibi Joseph reminiscing the glorious part of St. Aloysius.

A dream does not become a reality through magic, it takes sweat, determination and hard work. The path etched by Fr. Amedee Delalex has stood the test of time and is still relevant in the modern times.

INVESTITURE CER



'SCHOOLS' LITERARY COUNCIL'



INVESTITURE CEREMONY

→ To inculcate the sense of responsibilities in students and to groom the leaders of tomorrow, our school celebrated the oath taking ceremony of the office bearers for the academic session 2016-17 on 16th July 2016 with great enthusiasm.

The investiture ceremony commenced with the traditional lighting of the lamp by Hon'ble chief guest Dr. Ajinkya Kale, Senior Superintendent of post office, Jabalpur Division, principal Rev. Fr. Sibi Joseph. Hymn to St. Aloysius was sung with great pride, honour and respect by the school choir. The programme concluded with vote of thanks by the school vice captain, pledge by school captain, followed by National Anthem.

LITERACY COUNCIL

→ A student's life is a replica of a flower, just by watering the flower it blossoms day by day similarly just putting certain moral values, informative knowledge a student's life grows day by day and henceforth, activities, functions and competitive analysis are held to keep up the students to a great level by elaborating their minds through these activities which include Elocution, Extempore, Group Discussion, Debate.

QUIZ COMPETITION

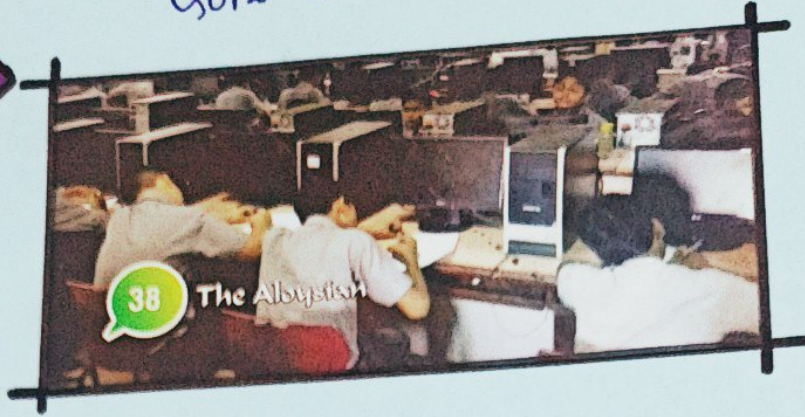

EXTEMPORE

COMPETITION



ELECTION COMPETITION



INTER-CLASS QUIZ COMPETITION

→ A quiz competition was organised in the school based on school history of St. Alaynius School, current affairs and C.K. for high school students. The aim of conducting the quiz was to test the students' knowledge related to school history, current affairs, sports event, science technology, books and authors, famous places of India, important dates in Indian History, famous leaders etc. The participants for the quiz were short-listed through various stages of selection.

EXTEMPORE COMPETITION

→ Extempore competition was organised by St. Alaynius Sr. Sec. School, Cantt Jabalpur for classes I to X on 23rd July 2016. The programme was presided by the principal Rev. Fr. Bibi Joseph and vice principal Mrs. Joyce Pereira. Our honourable judges for the competition were Mrs. Hilda Callaghan, Mrs. Kevin Pereira and Mrs. Sunita Sharma.

ELOCUTION COMPETITION

→ The ability to communicate effectively and skillfully is fundamental to students' development. To enhance this, St. Alaynius Sr. Sec. School, Cantt. organised elocution competition for classes I to XII where in students are trained.

DEBATE COMPETITION



CAREER COUNSELLING PROGRAMME



REPORT WRITING COMPETITION



INTER SCHOOL DEBATE COMPETITION

→ The ability to communicate effectively and skillfully is fundamental to students development. On behalf of the Christian Association our school had organised an Inter-School Debate competition on 21-Dec-16 under the able guidance of Rev. Fr. Sibi Joseph and Mrs. Jayce Pereira.

The competition had three tough rounds. The winners were awarded by the Rev. Fr. Sibi Joseph. The Rolling Trophy was awarded to St. Joseph's convent Sr. Sec school (TFRI) for securing the maximum points in the competition.

CAREER COUNSELLING

→ "If a child is given a subject of his interest, there are complete chances of Best outcome"

Normally it is experienced that students find it very confusing and difficult to decide as to which stream to select and why. Choosing career or deciding after passing 10th standard is very crucial and important as the career of the child solely depends on the correct stream chosen.

REPORT WRITING COMPETITION

→ Every child was tested for their writing skills in English by conducting a Report writing competition in English.

Master Chef



143rd ANNUAL ATHLETIC MEET



MASTERCHEF ✨ READY

→ Master Chef competition was organised for the students just before the science and craft exhibition. The sole purpose of the activity was to make students aware of healthy eating habits. Further, the activity also helped them to know about various cuisines around the world and how packing healthy and nutritional tiffin boxes was easy.

Students enthusiasm was overwhelming and their performance was praiseworthy.

SPORTS

→ The Mayrian sport Flag was introduced this year and inaugurated in the school staff room on 9th December 2016 by our principal Rev. Fr. Sibi Joseph.

The annual sports 2016 marked another mile in a significant change by creating a sports mascot. Our sports mascot - Swampi a Swampdeer is the animal of Madhya Pradesh and occupies a place in the list of endangered species.

MEANINGS OF THE SCHOOL EMBLEM

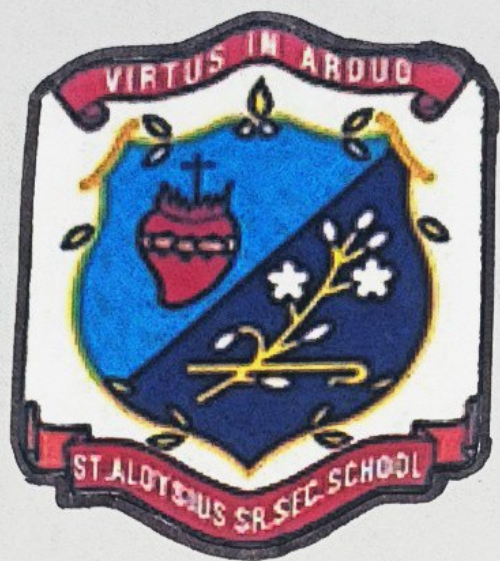

HEART SYMBOLIZES : Every Aloysian is expected to be tender, loving, affectionate and caring.

LILY SYMBOLIZES : Every Aloysian is to be endowed with sweetness, purity, humility, modesty, simplicity and happiness.

CROSS SYMBOLIZES : Sacrifice, self giving, love it reminds every Aloysian it is in giving and sacrificing oneself like Jesus in the service of others, one finds meaning for one's life.

“

Few Students Wrote About Their School ”

→ Good education, well trained faculty, disciplined children, promotion of health and well being of others as well as cleanliness.

- Rashi Agarwal IX.

→ The education is very, they teach us very well? teachers clear doubt very well. They maintain the cleanliness, they are bit strict about the uniform but it is they main the dignity of the school.

- Sanya Hirani IX.

Teachers in our school are very-kind and finally friendly with the students. School provides good, educational, sports etc, facilities.

- Saksham Anora IX

ST. JOSEPHS CONVENT
GIRLS'

SR. SEC SCHOOL

JABALPUR (MP)

1873





ST. JOSEPH.
Heil. Joseph.

INTRODUCTION

ABOUT PATRON SAINT

→ St. Joseph is a figure in the Gospels who was married to Mary Jesus Mother and was Jesus's legal father. Joseph is venerated as St. Joseph in the Catholic Church, Orthodox Church, Oriental Orthodox Church, Anglicanism, Lutheranism, and Methodism, and is also known as 'Joseph the carpenter'. Some differing views are due to theological interpretations versus historical views.

In both Catholic and Protestant traditions Joseph is regarded as the patron saint of workers is considered and associated with various feast days. Pope Pius IX declared to be both the patron and the protector of the Catholic Church, in addition to his patronages of the sick and of a happy death, due to the belief that he died in the presence of Jesus and Mary. In popular piety, Joseph is regarded as a model for fathers and has also become patron of various dioceses and places.

Several venerated images of Saint Joseph have been granted a canonical coronation by the Pope.

“ MEANING OF THE EMBLEM ”



Every Institution has an emblem which gave it its particular identify ; so also St. Joseph's convent S. Sec School , has its own significant emblem with its motto inscribed on a shield. Every Josephite must know her emblem and its meaning and be worthy of it. To become noble in character is an arduous life long task , " Rome was not built in a day " .

The lily is symbolic of the pure life of St. Joseph. Every Josephite must strive to be gentle , simple , pure and good , for that is the glorious flower of womanhood .

ABOUT SCHOOL



St. Joseph's convent girl's senior secondary school is a girls' convent school located in the city of Jabalpur, Madhya Pradesh, India. It is an English medium school for girls affiliated to the CBSE, New Delhi. It conducts classes from kindergarten to the senior secondary level.

The school was founded in 1873 by the Indian Province of the sisters of St. Joseph of Chambéry. It is administered by the sisters of St. Joseph Convent, Jabalpur in accordance to the general rules governing the above congregation. Saint Joseph is the patron saint of the school. Currently Sr. Navya is the principal of the school.

The pioneer institutions of Jabalpur in the field of education. The great traditions of the past are maintained and improved upon as the years go by.

SCHOOLS' ENTRANCE

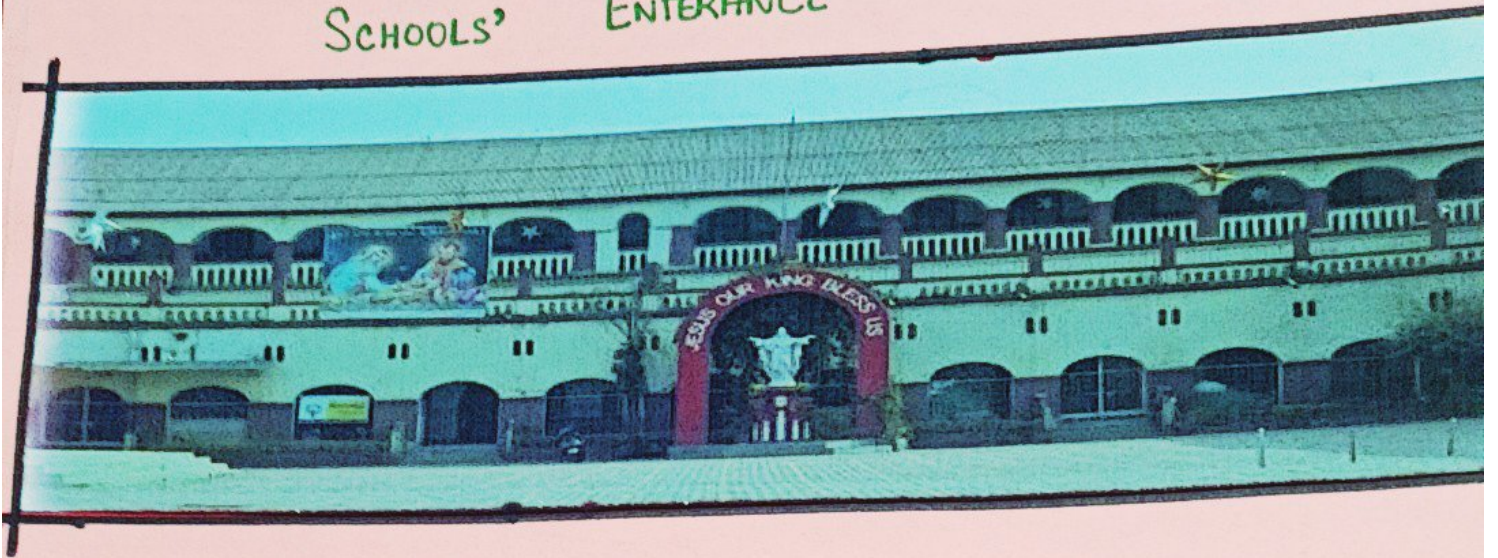

MULTIPURPOSE HALL

ST. JOSEPH'S MULTIPURPOSE HALL



BRIEF

HISTORY

→ JESUS CHRIST is the reason of our school and St. Joseph's convent girls senior secondary school, is lovingly placed under the protection of St. Joseph, the foster father of Jesus.

St. Joseph's convent was founded in 1873 by the Indian Province of the Sisters of St. Joseph of Chambey as per provisions of the constitution of India Part III article 30 (i). It is administered by the sisters of St. Joseph's convent, Jabalpur in accordance with the general rules governing the above congregation.

It is an English medium senior secondary school for girls affiliated to the CBSE, New Delhi. It conducts classes from the primary to the senior secondary level.

The school is lovingly dedicated to St. Joseph the foster father of Jesus Christ with its motto 'Virtue Alone Enables'.

SCHOOL'S PREMISES



WITH PRINCIPAL
SISTER NAVYA

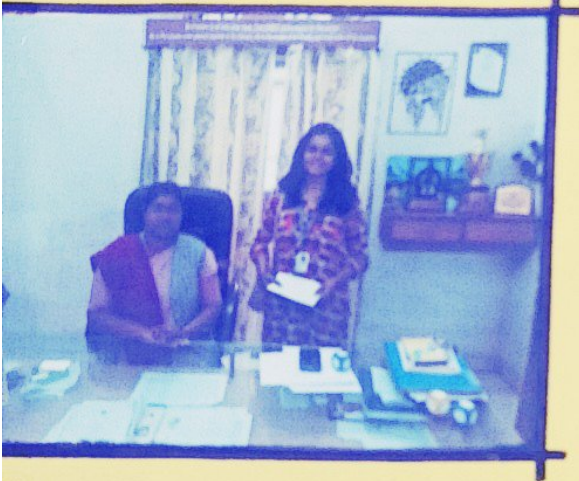

WITH STUDENTS



Topic _____ Date _____

St. Joseph the patron of our school, is called a 'Just Man'. In Holy scriptures - A man after God's own Heart. He was a simple carpenter, hard working, compassionate and available to those in need. He was ever ready to serve. He walked humbly before God.

Every Josephite, teacher and student, must emulate St. Joseph by being a simple, obedient hardworking woman of Faith and courage, to take her place with her counterparts in the world.

This institution which is 148 years old, is one of the pioneer institutions of Jabalpur in the field of education. The great traditions of the Part are maintained and improved upon as the years go by. The top priority of this school is the overall development of the pupils, through various activities with special emphasis on moral values and academic excellence. Due to importance to physical development through games and sports also give.

PICTURES OF SCHOOLS' PREMISES

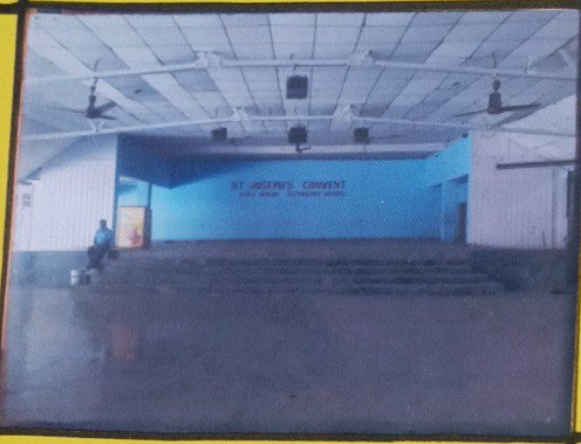
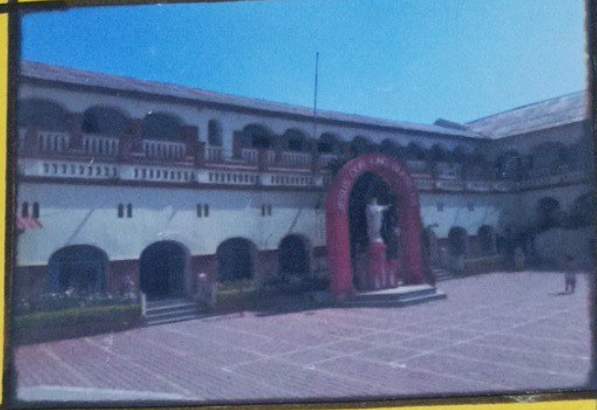
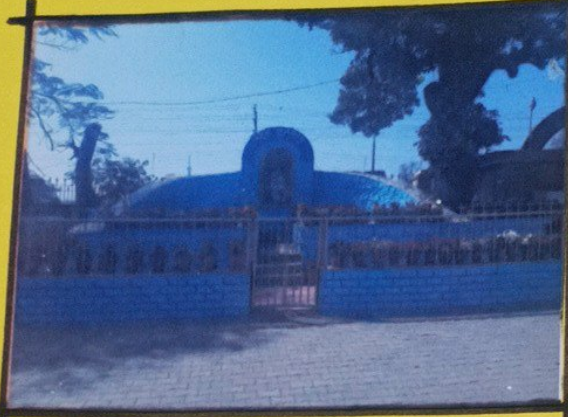

Jesus Christ is the reason for our School
The Patron of our school is Saint Joseph
St. Joseph is the foster Father of Jesus
JESUS is the unseen but ever present TEACHER
The School is managed by the Order of the Sisters, S.M.
The Founder of the Order is Fr. John Peter
The school was established in 1873
The Motto of the school is 'VIRTUE ALONE ENNOBLES'

WITH GIRLS'

IN SCHOOL

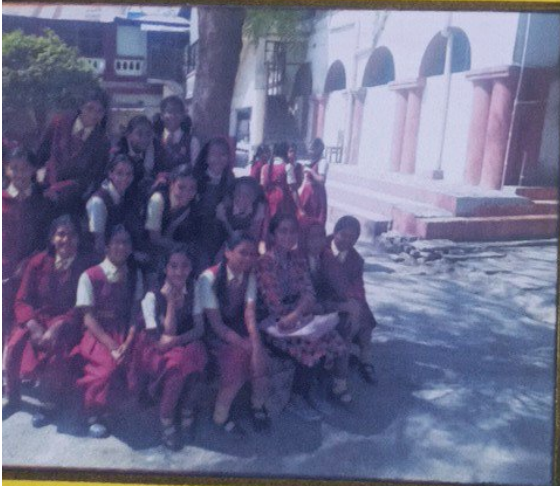

Topic _____ Date _____
Thus in keeping with the motto of our school - "VIRTUE ALONE ENNOBLES", every year our institution turns out young women of character, balanced in mind, body and spirit - in service of mankind and the nation.

Education must be a partnership between the school and parents if we are to prepare our children well to meet the challenges and needs of the future. Hence we need your co-operation dear parents, in this connection. This Diary is a liaison between the parents and the school. Any problem regarding the ward, may be conveyed through the school Diary, or you may seek an appointment with the principal.

Cooperation with school and instructions to the child to abide by the regulations of the school.

"May our divine Graces fulfill our vision and aspirations for all the students who pass through the portals of Saint Teresa's Convent".

SCHOOL SENIOR STAFF .



SCHOOL PLAY AREA



AIMS & OBJECTIVES

→* Integral formation of the person, enabling the students to become aware of the world, its people, its diverse cultures and problems.

* To prepare the students to function in her chosen career with infinite faith in God.

* Doing everything for the glory of God and the good of one's neighbour.

To give all round education - literal, technical, physical, moral, and spiritual, especially for CATHOLICS for whose education the school is established and to the extent possible to children of all communities.

To achieve this, the sisters draw their inspiration from Jesus Christ who lived and died for the liberation and development of every person.

PICTURES WITH GIRLS' IN SCHOOL PREMISES

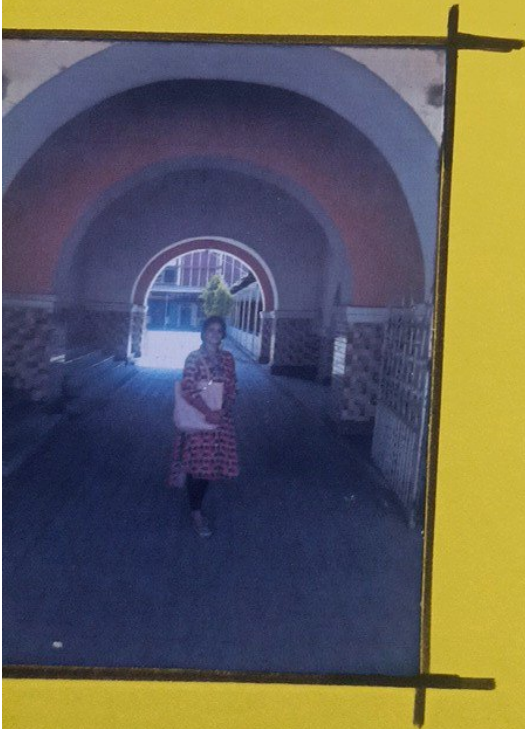
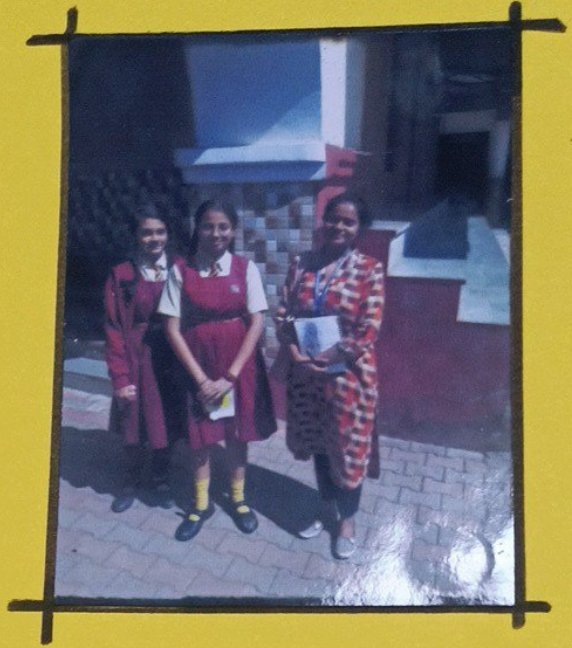
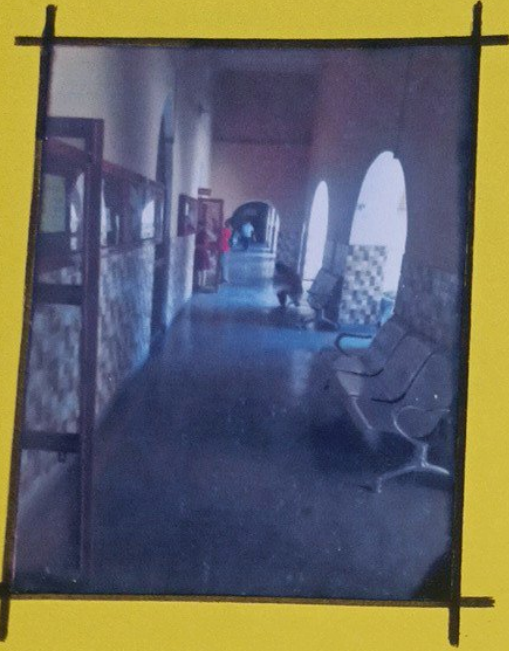

VISION



March 19, 2011 will go down in the annals of St. Joseph's convent as a historic day - a day on which the long-cherished dream of a new branch came to its fulfillment. It was on this day that the new school branch at TFR1 was inaugurated.

The germ of this idea was sown in the mind of our principal, Sr. Roselyn at the time of admissions for the new session. Over the years, while the city's population doubled and trembled, there naturally arose a demand for more schools. In response to this, schools and colleges mushroomed all over the city. However, no matter how many educational institutions come up, when it comes to the education of their child, parents always give preference to one that has proven its credentials through a rich history. This is a condition fulfilled by just a handful of schools in the city, SJC being one of them.

Administrative Staff



EDUCATIONAL TRIPS



CAREER COUNSELLING



Not surprisingly, then there used to be a clamour for admissions with the hopeful parents thronging the school the school office. Given the constraints of space and infrastructure, it was impossible to accommodate all the demands.

However, with our principal Sr. Roselyn, a problem cannot remain a problem for long. With her insight, experience and her habit of coming up with -out of box ideas, she cannot rest till she has solved the problem. So, if children cannot be given admissions because of constraints of space, the solution lies in expansion, in branching off.

“Ask, and it shall be given you, seek and ye shall find knock, and it shall be opened unto you.”
(Matthew - 7.7)

Provinced seemed to fall in with Sr. Roselyn's plans. Within no time, land was landed and acquired in Padanua near TARI colony and construction began. Stone by stone, brick by brick, pillar by pillar - a dream began to take shape.

SCHOOLS' ASSEMBLY



EXHIBITION



SCHOOLS' SPORTS ACTIVITIES

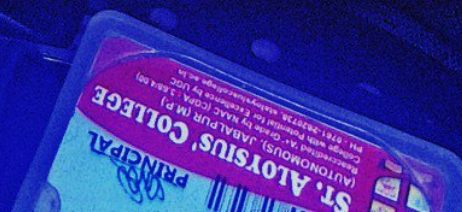
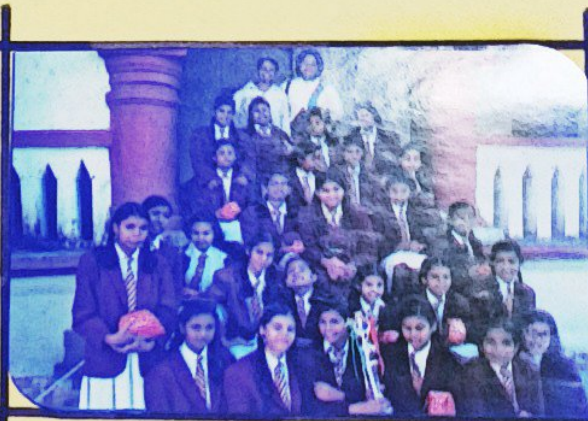

It was a labour of love and on the 19th March 2011, the feast of our patron saint, St. Joseph, this dream was dedicated to the service of society.

Set on the banks of river Goueri, amidst the scenic backdrop of lush green surrounding the school's environs, imbued with positivity and vibrancy. Huge airy classrooms fitted with a amenities provide a conducive environment for learning. A dedicated staff, an able administrator in the form of Sr. Nani at the helm and the guidance of Sr. Roselyn have ensured that the branch at TFKI maintains the same standards of excellence as established at the main branch. This is borne out by the fact that the performance of the students in both academic and extra curricular activities has not been lacking in any way.

ANNUAL FUNCTION



EVENTS

→ Children are a store house of talents, the only thing required and showcase these talents. Cultural programmes in the school are a step in this direction. To ensure complete participation in the senior classes, we spread our programme over a period of four days.

ANNUAL FUNCTION

An entire fortnight was devoted to the annual functions, the first one being that of the kindergarden on the 1st of December. This was a spectacular display of the performances of building siagers, dancers and actors. The dancing acrobatics in 'Bhangra' and the 'Rajasthani Dance' had the hall resounding with applause.

The second annual function was that of the middle and senior school on the 7th of December 2012. More than 600 students participated in the various songs, dances, skits and plays. The

ANNUAL SPORTS MEET



INVESTITURE CEREMONY

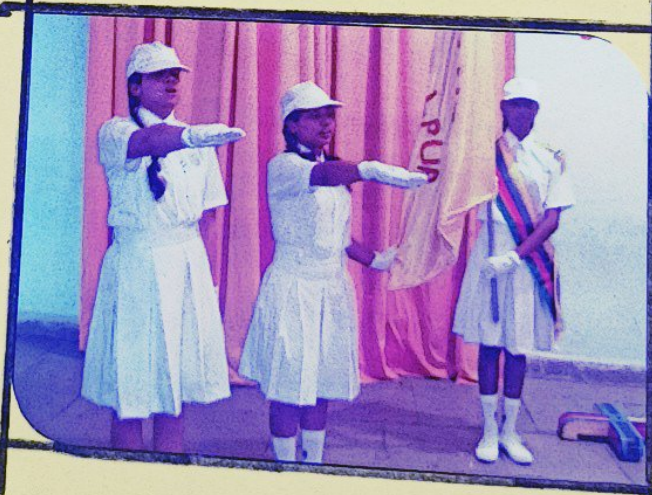

graceful dances of Bengal and the energetic ones of Punjab and Rajasthan had the audience enthralled.

ANNUAL SPORTS MEET

→ Sports and Athletics have been an integral part of St. ~~Atulya~~ Joseph S.S. School for years immemorial. Keeping up the traditions, this year too, the school organised its 140th Annual Athletic meet with same flamboyant spirit.

Apart from commemorating victories, this sports Day also witnessed a change and a new chapter of innovation. Flexibility, hard work and stamina mesmerizing the audience with their energetic performances. The students performed various stunts that included jumping through fire rings which was the attraction of the show.

INVESTITURE CEREMONY

→ To inculcate the sense of responsibility in students and to groom the leaders of tomorrow, our school celebrated the oath taking ceremony

RANGOLI - MAKING COMPETITION

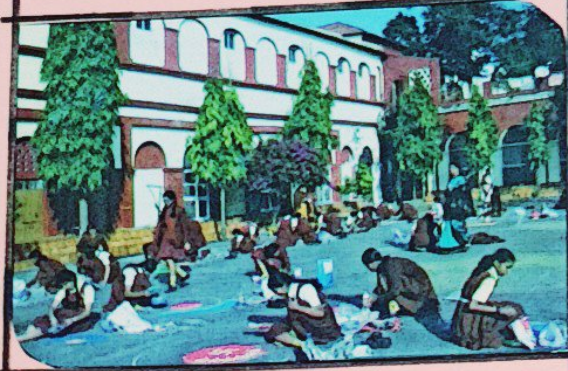

THALI DECORATION



COUNSELLING



SCHOOL BAND



of the office bearers for the academic session with great enthusiasm.

The program concluded with vote of thanks by school vice captain, pledge by school captain, followed by National Anthem.

RANGOLI, FLOWER-MAKING, THALI DECORATION CELEBRATIONS

→ The Rangoli making, flower making Thali Decoration competitions are held within school premises, in which children from different age groups take part enthusiastically and showcase their knowledge and creative skills in their art works.

The competitions concludes with the announcement of winners in all the categories.

CHRIST CHURCH BOYS'
SENIOR
SECONDARY SCHOOL

JABALPUR (MP)

1876

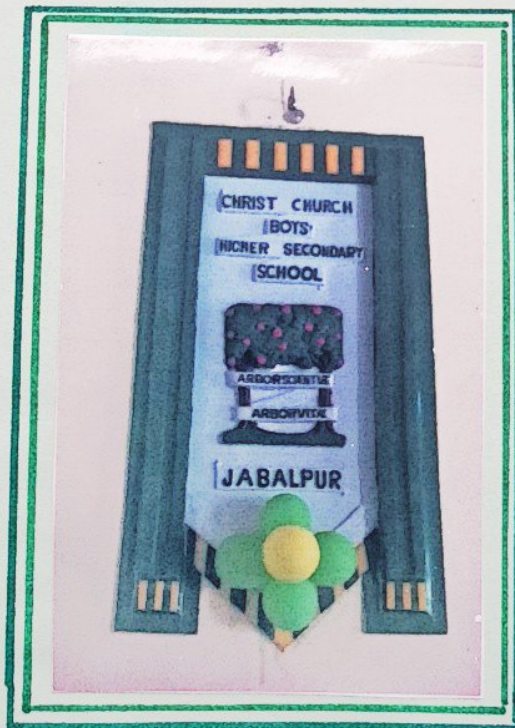

CHURCH OF NORTH INDIA EMBLEM

CNI EMBLEM - A UNITING SYMBOL
Designed by Frank Wesley



The **CIRCLE** in which the whole design is enclosed is a symbol of eternity, for it is without beginning and without end. We believe and remember that behind the ebb and flow of things temporal, there stand the eternal truths.

Dominating the whole design is the **CROSS**. It stands for self giving and self sacrifice. It was the Son of God who suffered and died on Cross for us. It is a golden Cross; gold is sign of victory and symbol of triumph.

The Cross is set against a background of **RED**. Red is the colour of blood and symbol of sacrifice and self giving. It stands for the Holy Spirit to whom we always look for guidance, who led the church into unity.

Behind the cross there is a **LOTUS**. It is our national flower and is symbol of purity and spiritual quest of India. It rises to all its own pure beauty out of mud. It inspires us to rise and shine.

The **CHALICE** which is used in Lords supper is set at the very centre which teaches us that worship and sacrament are at the centre of Christian living. It is set against a background of red. But the Chalice itself is gold, for the sacrament is God's gift of His own life.

In the outer circle there are three key words which is the motto of CNI "**UNITY - WITNESS SERVICE**".

CHURCH OF NORTH INDIA IS UNITED AND UNITING CHURCH

DESIGNED BY - FRANK WESLEY

INTRODUCTION

FOUNDATION

→ The Christ Church began with the visit of the Bishop from Calcutta and the Archdeacon to Jabalpur in January 1841. Bishop Wilson, was also Bishop of India, East Indies, and Australia, and the Archdeacon was the Hon'ble Pratt. The Bishop laid the first stone for the Church which came to be called, "Christ Church".

The building progressed in leaps and bounds and was so advanced that by March 1843 it had begun to be used. Divine services started from April 1844. The main building and tower cost Rs. 2500/- . The bricks were made with labour of the prisoners.

The first Chaplain, The Revd. F. A. Dawson, was appointed by the Lt. Governor of North West Province, by an order dated 2nd January 1844. The Rev. Dawson arrived at Jabalpur on 26th February 1844. After his arrival the vestry costing 749/- was added to the Church building in 1845. The first Church committee was formed in March 1844 to help the Chaplain in the discharge of his duties. Sunday School was held in the Church vestry.

In 1869, the Revd. W.B. Drawbridge was appointed as chaplain. The Revd. Drawbridge was a remarkable man, for in the 4 years of his chaplaincy, he installed the lectern and brass altar desk at a cost of Rs. 320/- He also made plans to purchase a bell for the church. He was responsible for the consecration and opening of the present Mandla Road cemetery. He provided a new organ and added pews capable of seating 78 persons.

In 1870, the Revd. W.B. Drawbridge started the CHRIST CHURCH SCHOOLS with the help of Mr. G.P. Thomas, the Resident Engineer. He also planned to extend the church.

“ PICTURE OF SCHOOL PREMISES ”

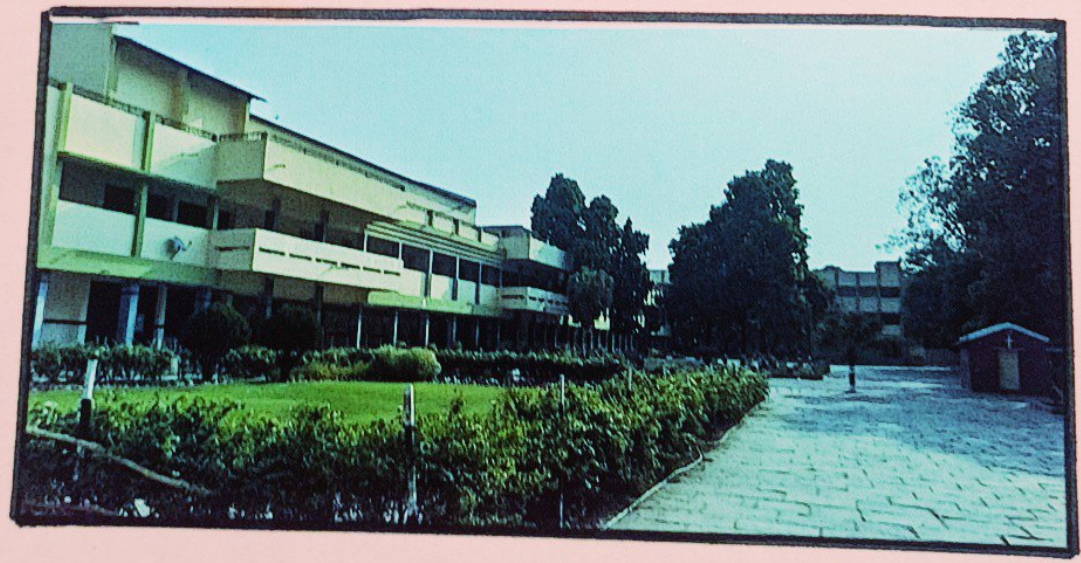

ABOUT SCHOOL

The Christ Church School had its beginnings in the vestry of Christ Church in 1870, and was then known as Christ Church School. The school was founded on 1 November 1876 by Rev. Drawnidge. The school started with three students and now there are over 3,000 students at the school, and 101 members on the teaching and office staff.

At present, the school functions under the Board of Education, Church of North India Jabalpur Diocese with the Rt. Revd. Dr. P.C.S. as Chairman. The education imparted is based essentially on the quintessence of Christian ideals and principles. It has a well qualified, dedicated and committed staff who teach pupils with extreme love and care. The school has so far served and contributed to the society for the past 145 years.

PICTURES OF SCHOOLS' OLD BUILDINGS

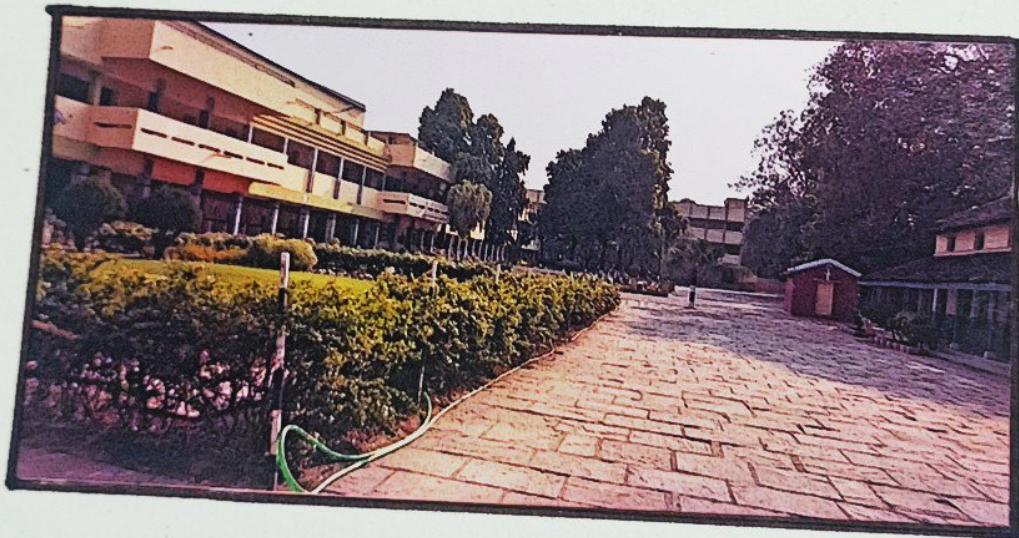
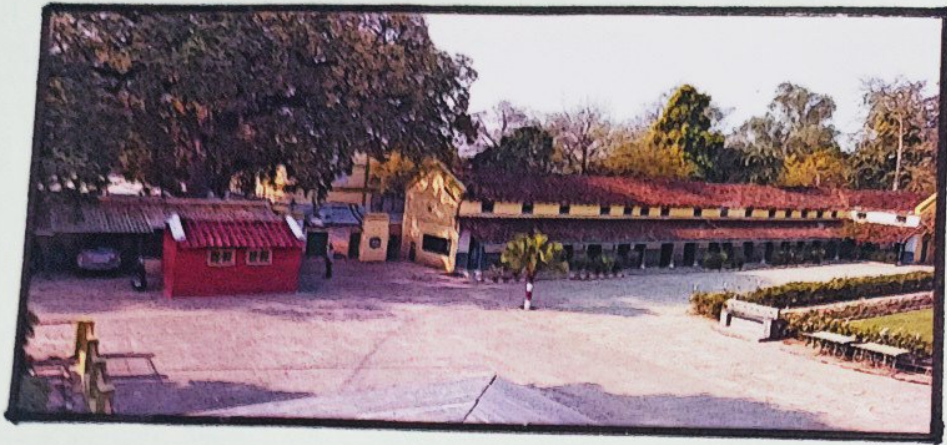

BRIEF

HISTORY

The Christ Church Boys' school owes its name to the Christ Church Cathedral, where it made its humble beginning in the verity of the Church on 1st June 1870,

The school was founded by the Chaplin, The Rev. W. B. Drawbridge and the associate founder Mr. G. P. Thomas (Engineer).

The school was run and administered by the Nagpur Diocesan Board of Education of former Anglican Diocese of Nagpur. After the formation of the Church of North India on 29th November 1970, the Diocese of Jabalpur was created as a new Diocese of the Church of North.

The school began its journey with just six children and now serves the cause of education to Board of education, Church of North India, Jabalpur Diocese. The school strictly adheres to the rules framed by the central Board of Secondary Education, New Delhi.

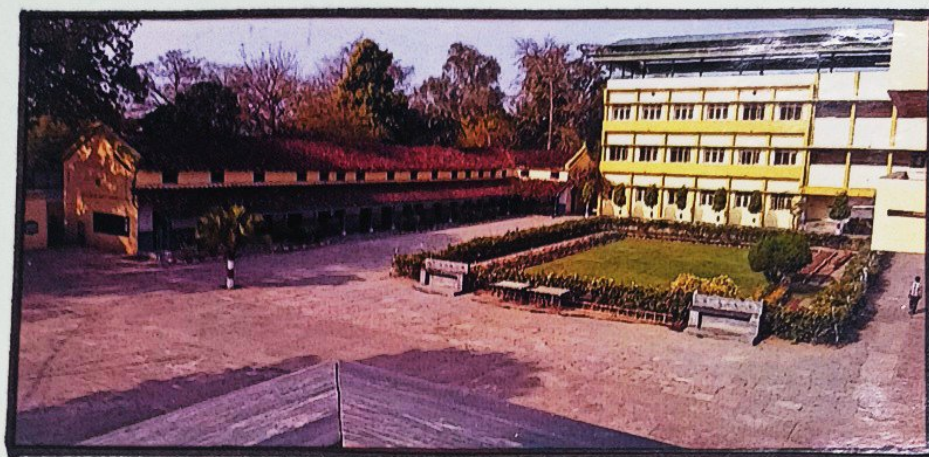

THESE CORRIDORS ARE STILL FROM FOUNDATION



THEY ARE NOT EVEN RENNOVATED

The education imparted is based essentially on the quintessence of christian ideals and principles. It has a well, qualified, dedicated and committed staff working under the multi-faceted leadership and dynamic personality of our Moderator CNI Synod, Bishop and Chairman of Jabalpur Diocese The most Rev. Dr. P. C. Singh the proficient and dedicated Principal Mrs. LM Sathe and the versatility and efficacious School Manager Mr. Suresh C. Jacob.

The most Rev. Dr. P. C. Singh, the present chairman of the Board of education, Church of North India, Jabalpur Diocese is the fourth Bishop of the Jabalpur Diocese and the first Bishop of the Jabalpur Diocese to become the moderator of the CNI Synod. Under visionary leadership and prescient knowledge, the Christ Church Boys' Senior Secondary School has taken another leap towards academic excellence by establishing its branch, Christ Church Co-Ed, at Saliwada in 2015.

"May the Almighty shower his everlasting blessing to lead, guide and preserve the school in its future Endeavours"

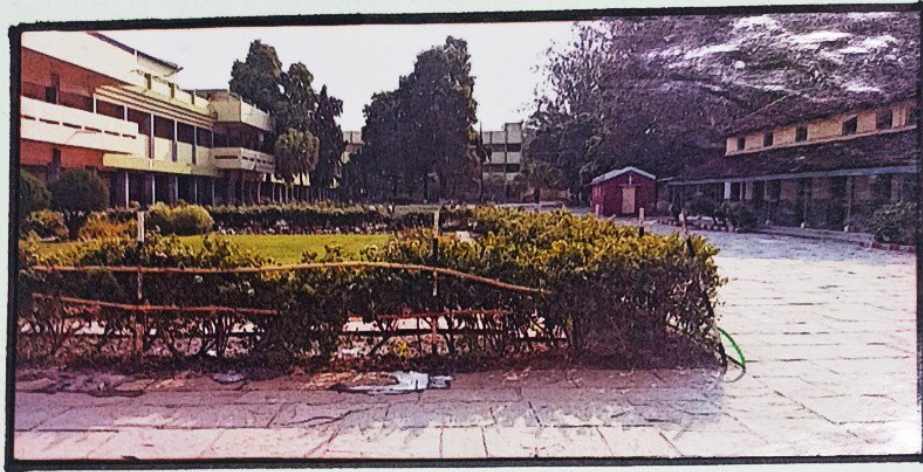

CLASSROOM PICTURES OF THE BUILDING

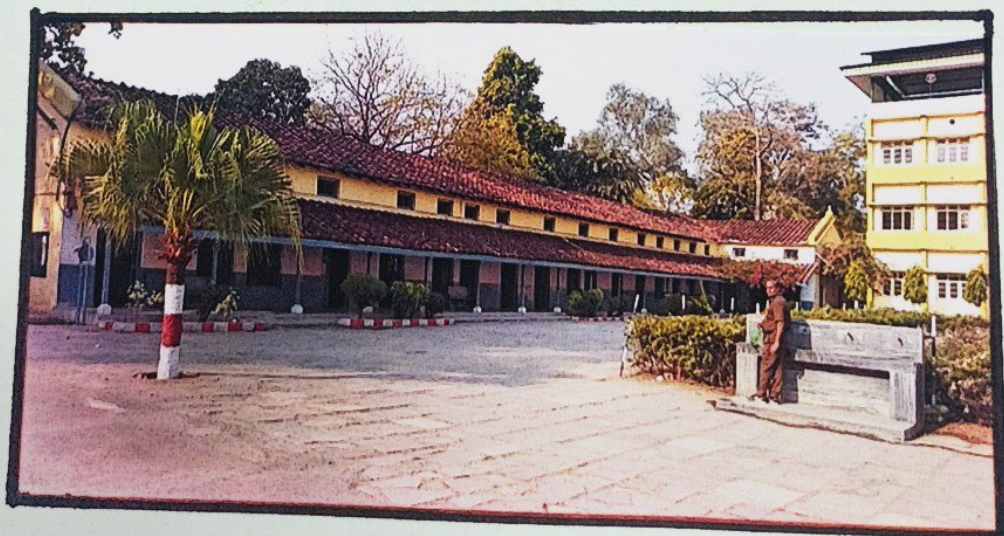
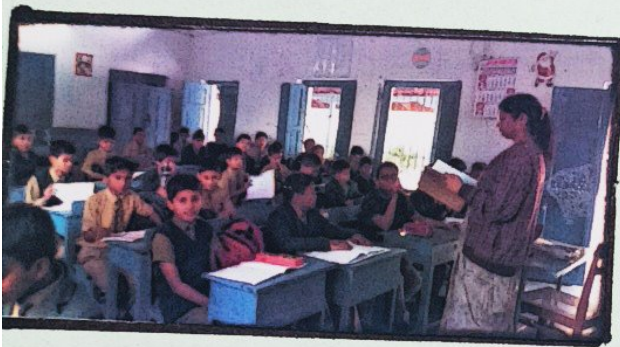

OBJECTIVES

A progressive approach is an inevitable part of the Christ Church Boys' Senior Secondary that has consistently contributed in improving and strengthening the society.

The school AIMS at building students with conscience, competence, compassion and commitment. It also provides a holistic development through character building and disciplined education.

The MISSION is to nurture the different strata of society by imparting knowledge and unlocking the true potential of the young minds.

Ever since its establishment, academic excellence has been the VISION of this institution. Our deep rooted communication has been to propel the students to imitate values and ideals inherited from our founders, towards a wider Horizon.

"We uphold the laurels of our past as excellence remains a never ending search."

SCHOOL LIBRARY

ACHIEVEMENTS

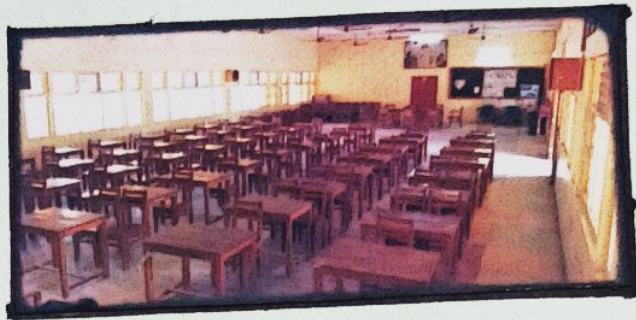

WALL WITH NAME OF ALL THE



SCHOOL CAPTAINS

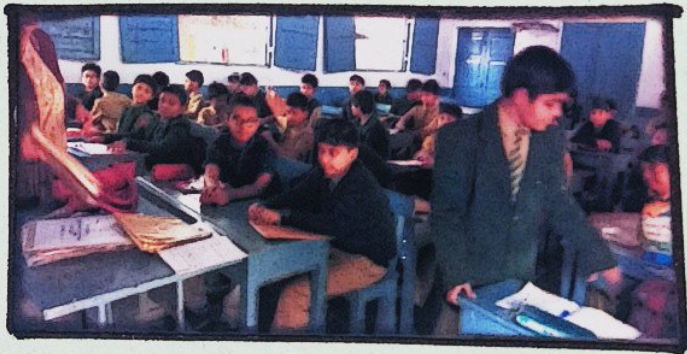

GOALS

The institution, founded in 1870 believes that education is fundamental in making a positive change for individuals, groups, communities and society as a whole.

They pledge to achieve the following goals :-

- Provide tools and nurture the comprehensive and communication skills in the English language, in order to boost their SELF CONFIDENCE.
- Craft, an innovative learning experience which ENCOURAGES creative thinking in a collaborative, technology-rich ENVIRONMENT.
- Generate a rich and varied experience in the CURRICULUM, thus developing leaders in different facets of both SCHOOL LIFE and FUTURE.
- Establish an environment which counsels both staff and students to practice ETHICAL and MORALLY, COURAGEOUS Behaviour.

PICTURE OF JUNIOR BOYS SCHOOL

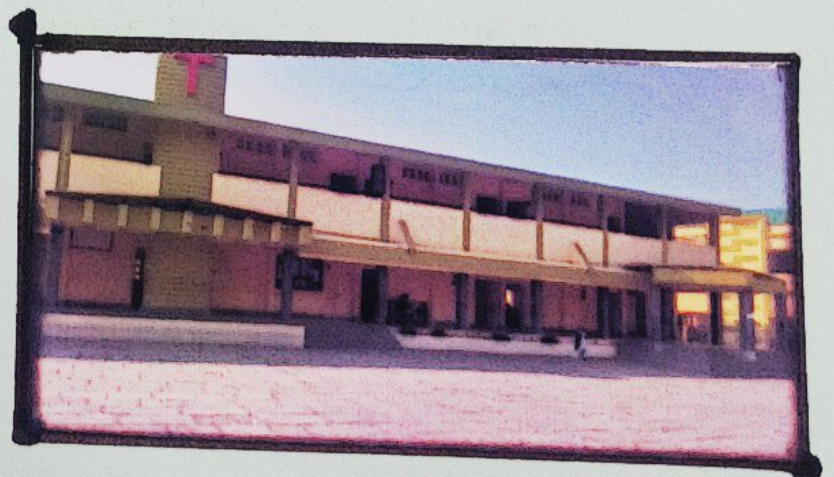
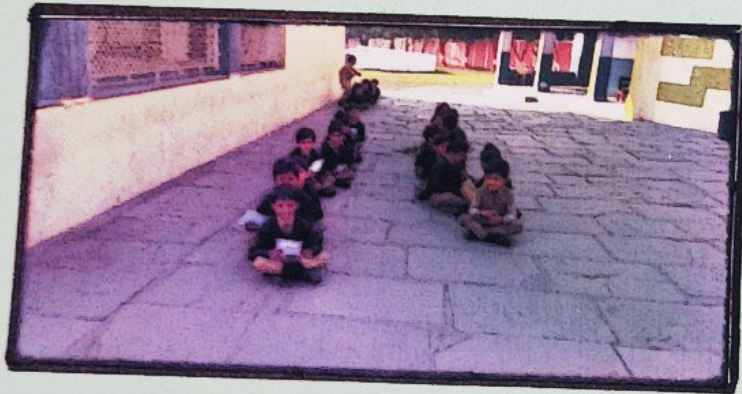
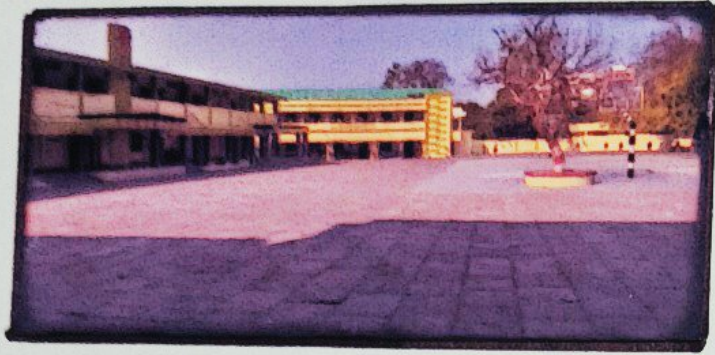

ACADEMICS

→ The academics of Christ Church Boys' Senior Secondary School strives towards exhibiting excellence and outstanding achievements. It envisions a robust and vibrant education that opens new avenues for enriching life.

* The school was 'earlier' affiliated to MP Board.

→ The school has classes from Nursery to XII. The medium of instruction is English. The school is affiliated to the central board of secondary Education.

SUBJECTS TAUGHT

ENGLISH as a core language is compulsory at all levels and enjoys the status of the first language since the school is an English medium school.

HINDI is taught as second language.

SANSKRIT is taught as the third language from class VI to VIII. Other subjects are taught as per the syllabi prescribed by the central board of secondary education.

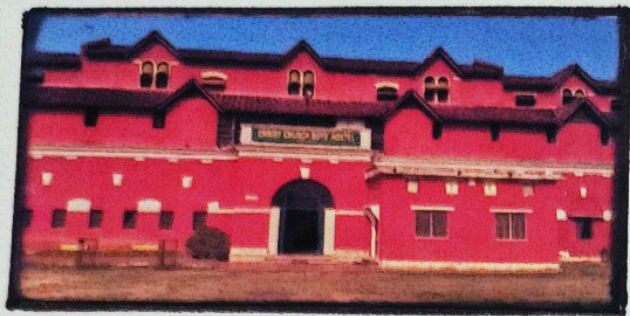

CHRIST CHURCH BOYS'
HOSTEL

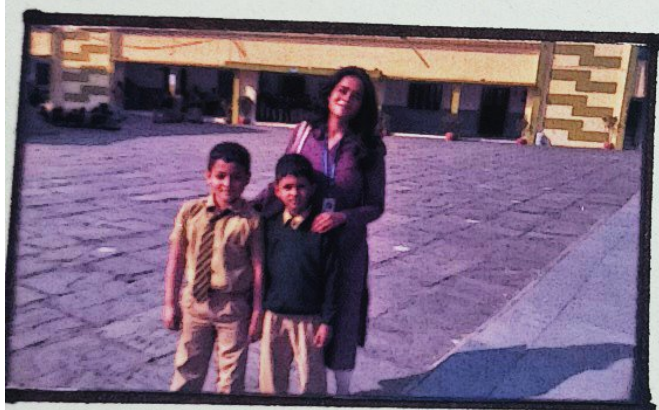
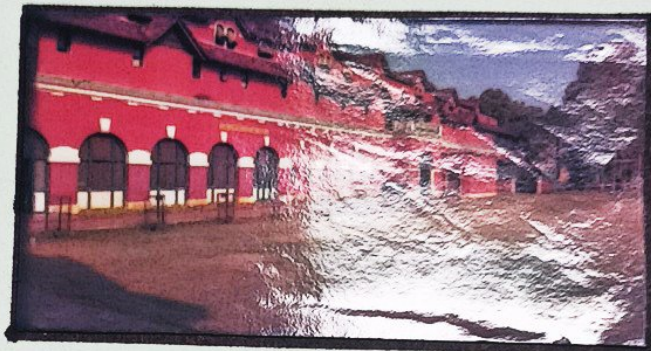

HOSTEL
GROUND



CHOICE of Subjects At +2 level is strictly on merit. The successful candidates at class X level may select any one of the two schemes of studies of their choice as given below. These will be subject to conditions of eligibility governing each and will be intimated along the Board results displayed on the Notice Board.

The CBSE does not permit any change of subject once the option is made. No change of subject in class XII will be endorsed by the Principal.

A. SCIENCE STREAM

English, Physics, Chemistry, Mathematics, { optional - computer science, Hindi, Physical Education (any one)

English, Physics, Chemistry, Biology, { optional - Computer science, Hindi, Physical Education (any one)

B. COMMERCE STREAM

English, Economics, Accountancy { Business studies / Info Practices } { optional - Hindi, Mathematics, Physical education (any one) .



INVESTITURE

CEREMONY

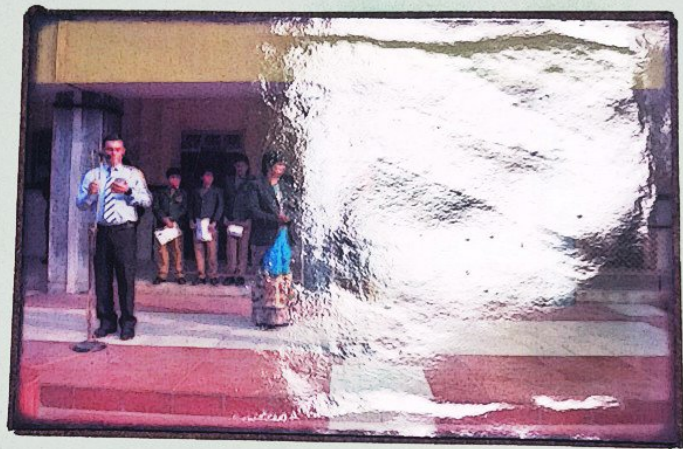

FOUNDERS'

COMMEMORATION

CEREMONY

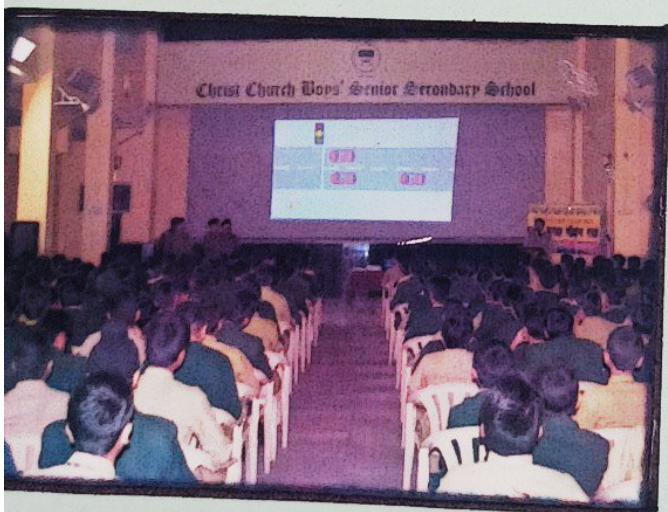

EVENTS

- The myriad traditional activities held in the school over the successive years still continue to bring laurels to this institution.
- At the commencement of the authority academic session, the INVESTITURE CEREMONY at the Christ Church Boys' school confers authority to the nominated Prefect council. The elected representatives of the houses adorned with their colourful epaulettes, pledge to dispense their duties with loyalty and to serve the institution ensuring the ethos of the school.
- The Founders' Commemoration Service is celebrated every year on 1st November at the Christ Church Cathedral. On this special day, the school pays tribute to the patrons who through their academic initiatives, have enriched the lives of multitudes for generations. On the same day, the Prefect council, bearing the house colour flag, solemnly march to the chancel where the congregation participate in a Thanksgiving service and the Presbyter evokes divine blessings for the school.

SCHOOL BAND



TORCH LIGHT PERFORMANCE



- The School Band is the Backbone and the glory of our school. It constitutes a select group of children from classes VI to XII who are well trained in 'Threes Marching, Circle Marching, Bugler and Drummer Group Marching' and many more drills. The marching contingent gives an impressive display of its prowess on important occasions.
- The Road Race event is held every year in remembrance of Major General and Mrs. W.T. Wilson of Madhya Pradesh (Independent) Sub-Area Jabalpur. With the rays of the sun illuminating the early hours of the morning, our young and enthusiastic athletes gather on the primary school ground where the students as spectators witness, cheer and applaud their favourite contenders.
- The Founders Annual Athletic Meet is held amidst great mirth, veer and comradeship. The spectacular team working competitive game Tug of War is conducted every year amidst great thrill, shreel and cheer with each house tugging the rope and challenging their test of strength and endurance. The sports day also involves mass student participation with a well synchronised March Past by the different houses parading in precision, splendid fields displays, various challenging track events and exciting Inter House Relays.

MAIN GATE [ENTERANCE]

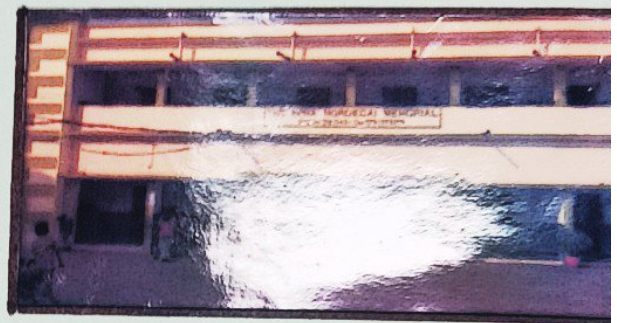

PREMISES PICTURES



The FOUNDERS ATHLETIC MEET is held amidst great mirth, veer and comradeship. The spectacular team work competitive games.

→ The most intriguing and embellishing event is the Torchlight Display - a legacy of our founder Mr. D.V. Beatson. It is symbol of innovation showing excellence with uniqueness. At dusk, the senior school students bearing lighted torches perform the exercises with dexterity and dispel the darkness from around.

→ The Inter School 2nd Lieutenant David Deva Vir Chakravarti Memorial English Debating Competition and the Madhav P. Tare Hindi Debating Competition is held between the Christ Church Boys' Senior Secondary School and the Christ Church Girls' Senior Secondary School. The event is also a tribute to the Late Mr. B.B. Singh a former teacher of our school who pioneered this debating tradition 40 years ago.

→ Amidst the plethora of events, Elocution in school plays an integral part in honoring the talents of our students.

NATIONAL ROAD SAFETY WEEK.



NETAJI SUBHASH CHANDRA BOSE JAYANTI

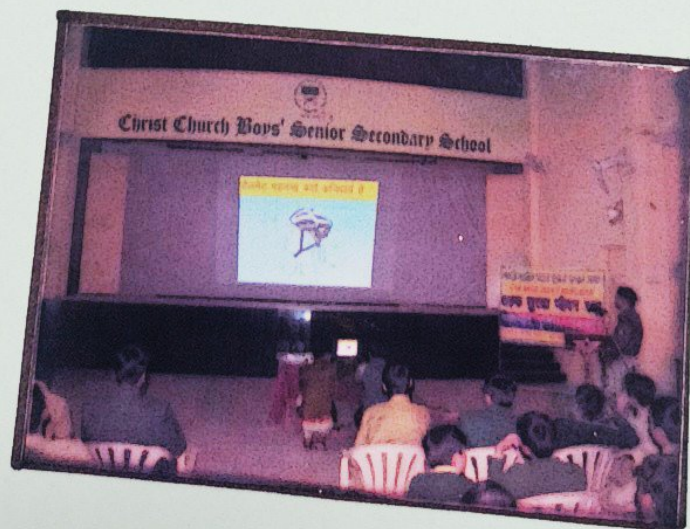

CELEBRATIONS

→ NATIONAL ROAD SAFETY WEEK

On 7th February 2019, 'National Road Safety week' was organised in the Robinson hall of Christ Church Boys Senior Secondary School. A seminar on 'TRAFFIC RULES AND REGULATIONS' was presented by the TIO of Omti Police Station, Mr. Neeraj along with his squad. The city police aimed to educate the youngsters about traffic rules and dangerous driving and over speeding. Importance of wearing helmets and seat belts was also emphasized. The seminar concluded with a vote of thanks and the hall echoed with the slogan "Sadak Suraksha - Jeevan Raksha".

→ NETAJI SUBHASH CHANDRA BOSE JAYANTI

Netaji Subhash Chandra Bose Jayanti was celebrated in Christ Church Boys school. The students of Class 7th spoke about the life history of Netaji. They also played the role of Netaji. His childhood and how he formed the Indian National Army (INA) were discussed by the students. Netaji's famous quotes including 'GIVE ME FREEDOM AND I WILL GIVE YOU FREEDOM' were shared by students.



PICTURES OF SCHOOLS' PREMISES



OF DIFFERENT PLACES

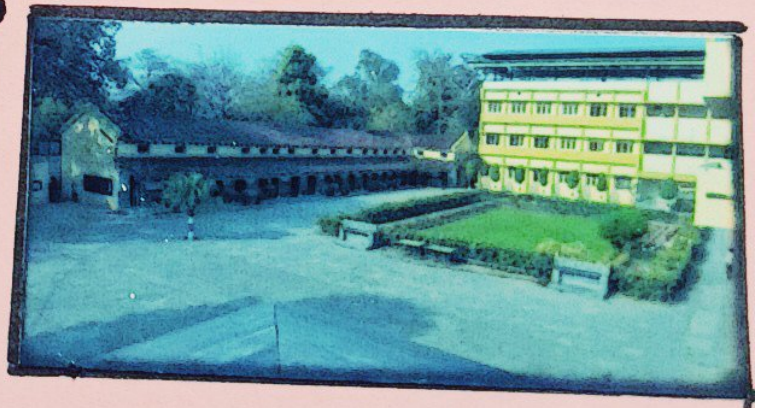

→ SPELL BEE COMPETITION

A class wise spelling Bee competition was organised in the school Robinson Hall on 17th January 2019. Students participated with great enthusiasm and they duelled through the toughest words. This competition was a wonderful learning source not only for the participants but also for their peers. This competition also helped in enriching the vocabulary bank of the students.

→ CARRIER GUIDANCE PROGRAMME

Career Guidance is an essential factor for identifying the real potential and it guides the students towards the right goal. A Career Guidance program was held on 16th January 2019, for the students of IX and X in Christ Church boys school, in Robinson Hall. The program which continued for 5 hours concluded successfully by words of encouragement from the Principal Mrs. LM Sathe.

“
SCHOOL STUDENTS WROTE FEW THINGS ABOUT
THEIR SCHOOL”



→ I like the academics of my school, And also the Physical education. Especially, I like the teaching of my school and my favourite subjects are mathematics and english.

- Chirag Maravi VIII 'c'

→ The best things of my school is the way the teachers teach us. The academics are really good. The co-curricular activities are also developed and sports is introduced in a perfect manner.

- Arsh Agarwal VIII 'c'

MEETING PRINCIPLE 'LM SATHI' MAM



The school is very supportive and provided images and information about the glorious parts of the school. They were very supportive.





CONCLUSION

It was an immense pleasure for me to **conclude** my assignment. This journey through out the making of assignment was full of **curiosity** to know more. Me and my mates enjoyed it to bits, while making the assignment and collecting information, which not only enabled us to explore the historical places of the city but also to know about their significance to us.

It imbibed the historical significance and beauty into our **hearts**, **mind** and **soul**.

It also emphasised upon the establishment and foundation of such important **educational institutes** in the city, and also the education system in prevailing time and helps us differentiate it with the current time.

However, the negligence about the institutes importance is a serious issue as it would just create unawareness about such part beauties. This assignment has helped me to acquire data analysis, research expertise and evaluation skills.

EBIBLIOGRAPHY

Information from few websites were very helpful :-

- * cebsss.org.
- * en.m.wikipedia.org.
- * staloyssivjabalpur.edu.in.
- * sjcsadar.org.
- * wikipedia the free encyclopedia.

Even these other resources were very helpful for assignment :-

- * The Aloysian Vol.92 (2016-2017)
- * The Josephite (2012-2013)
- * School Diary (Aloysians)
- * School Diary (Joseph.).
- * Prospectus of School (CCB)

x - x - x



ST. ALOYSIUS' COLLEGE

(AUTONOMOUS), JABALPUR(M.P.)

Reaccredited 'A+' Grade by NAAC (CGPA 3.68/4.00)

College with Potential for Excellence (CPE) by UGC

DST-FIST Supported & Star College Scheme by DBT.

SAMPLE PROJECT REPORTS

2019-20

FACULTY OF SCIENCE

St. Aloysius' College (Autonomous), Jabalpur

Project Report

on

"A study based on the state of mind of the students of St. Aloysius' College (Autonomous), Jabalpur, in different situations with regards to academics."

Patron

**Rev. Dr. G. Vazhan Arasu
Principal**

Co-ordinator

**Dr. Daya Shankar Gautam
Department of Zoology**

Place of Work

Campus of the College

Submitted by

**Swastik Kumar
Admission no.- 46173
M.Sc. Zoology (Semester-II)
Session 2019-20**

DECLARATION

I, **Swastik Kumar**, a student of M.Sc. Zoology, Semester-II (Session 2019-20) of St. Aloysius' College (Autonomous), Jabalpur would like to state that I have undergone a project at the Department of Zoology of St. Aloysius' College (Autonomous), Jabalpur on the topic entitled: "**A study based on the state of mind of the students of St. Aloysius' College (Autonomous), Jabalpur, in different situations with regards to academics.**" from 04/02/2020 to 09/02/2020, and this report has been genuinely prepared by me.

Name: Swastik Kumar

Signature:

A rectangular box containing a handwritten signature in cursive script that reads "Swastik Kumar".

ACKNOWLEDGEMENT

I respectfully thank Dr. Fr. Vazhan Arasu, Principal St. Aloysius' College (Autonomous), Jabalpur for giving me an opportunity to do the project work on the topic entitled: "**A study based on the state of mind of the students of St. Aloysius' College (Autonomous), Jabalpur, in different situations with regards to academics**" and providing me all support and guidance which made me complete the project on time. I am extremely grateful to him for providing such great support and guidance. I owe my profound gratitude to my project guide, **Dr. Daya Shankar Gautam, Assistant Professor, Dept. of Zoology** who took interest in my project work and guided me all along till the completion of the same by providing all the necessary informations for developing a good system. I would like to thank all the teachers of the **Department of Zoology** for their unlisted encouragement, and moreover for their timely support and guidance till the completion of the project work.

Name: Swastik Kumar

Signature: 

Objective:

To study the state of mind of the students from all the streams in St. Aloysius' College (Autonomous), Jabalpur, based on the different situations with regards to academics. Also, to understand as to how they deal with the situations like exam stress and pressure apart from their personal issues.

Introduction:

The most common issues faced by the students, at present, are stress and depression which are caused by a number of factors, of which, the main one being the academics. As we all need to understand the actual reasons behind such issues, hence we carry out certain related activities. A number of surveys have been carried out on the students worldwide to understand the psychological perspectives. Surveys concerning mainly about such psychological approaches help us understand the various aspects that are required to be dealt with such matters, which are the main concerns among youth in the present scenario across the globe.

Materials and Methods:

To begin with, the very first challenge was to find a suitable topic that would go perfect with the project I was supposed to work on. With the help of my respected guide, we together laid out a protocol that we had to follow throughout the survey, and also for making the questionnaire. The main concern was to understand the basics of the students' state of mind with regards to academics. In order to do so a set of 6 questions, out of which 2 consisted sub-questions, were being prepared which mainly focused on on the day-to-day happenings in the college environment as well as the situations relevant to the same such as the mindset of the students before, during and after exams.

In the questionnaire, there was a question about the "stage phobia" where my main aim was to understand the students' approach, even though some of them being prepared yet there is some sort of nervousness due to a number of reasons. Also, I needed to know as to how the try to overcome the fear which we know is very common among students.

A *pro-forma* was being prepared containing the questions on which survey was to be carried out. The original copy of the *pro-forma* is attached below:

**A study based on the state of mind of students of St. Aloysius' College (Autonomous), Jabalpur
in different situations with regards to academics.**

Name:

Date:

Age:

Gender:

Faculty: Arts Commerce Science

Family members: Mother Father Brother(s) Sister(s)

Questionnaire:

1. What feelings you get when you're asked a sudden question by a teacher in the class?
a.)Excited b.)Feel good c.)Normal d.)Nervous e.)Angry
2. How do you feel a day before exam?
a.)Excited b.)Feel good c.)Normal d.)Nervous e.)Stressed
i.) If stressed or nervous, how do you release it out?
a.)Listen to music b.)Watch Comedy videos c.) Chat with friends d.) Don't do anything at all
3. How do you feel on the day of exam?
a.)Excited b.)Feel good c.)Normal d.)Nervous e.)Disappointed
4. What comes in your mind when you find the question paper quite different from what you expected it to be?
a.)Excited b.)Challenging c.)Normal d.)Nervous e.)Disappointed
5. How do you feel on the day of result?
a.)Excited b.)Feel good c.)Normal d.)Nervous e.)Anxious
6. Do you have stage phobia?
Yes No
i.) If yes, then what do you do to overcome it?
a.) Willing to participate in extra-curricular activities b.) Participate only after being motivated
c.)Want to do something but haven't done d.)Don't participate at all due to lack of confidence

Signature of the Surveyor:

Name of the Surveyor: Swastik Kumar

I agree that the information furnished by me shall be used for scientific studies.

Sign of the Respondent:

Figure 1

The course of the field work (i.e. survey) was for 6 days, dated - 04/02/2002 to 09/02/2020. Some 250 to 300 students from all the streams, i.e., arts, commerce and science were being introspected, at random, so as to have an amalgamation of the choices they made to have a crisp knowledge about their mindset and also to figure out which areas they were good at, and to the ones they are lacking. They interestingly participated to fill out the questionnaire and they were being told to be genuine while answering the same, as their identities have been kept confidential because the main focus was to carry out a concrete conclusion based on the survey.

The respondents (students) have also been told that their choices will be taken as the prime source of this scientific research, and to do so there was a declaration being presented (at the end of the questionnaire) below which they had to put their respective signatures as this survey had to be of a great value to the studies that would be made later, and for which a mutual consent was being made between the surveyor (me) and the respondents.

In the end, a total of 250 forms have properly been filled by the respondents based on which the further data have been collected and laid out, and observations on the same have been obtained.

Observations and Result:

Based on the questions in the *pro-forma* (refer Fig. 1) and the responses opted by the students during the course of survey, a number of observations have been made which are tabulated along with the graphs that have been obtained are as follows :

Table 1 and Graph 1 : Contain the *streams* which the students belong to, and their categorisation based on the *numbers of students*. The table and the graph are as follows:

STREAM	NO. OF STUDENTS
ARTS	19
COMMERCE	63
SCIENCE	168
Total	250

Table 1

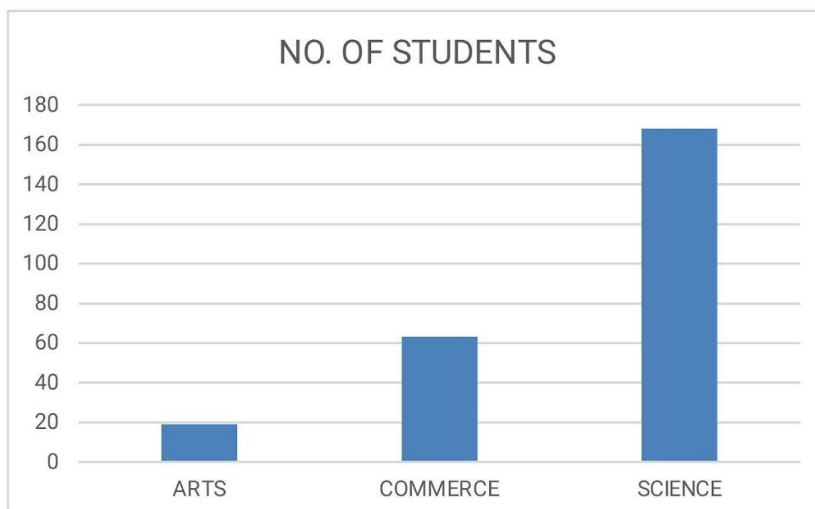

Graph 1

Observations:

- Out of **250** students who responded, **19** belonged to *Arts*, **63** from *Commerce* and **168** were from *Science*.
- If we look at the percentage stream-wise, then *Arts* students contribute **7.6%** of the total, *Commerce* accounts for **25.2%** and the rest **67.2%** is shared by the *Science* students.
- The respondents (students) were being introspected, at random, i.e., all 250 of them were from different years in their course of studies.

Table 2 and Graph 2 : Consist of the respondents from the *Arts* stream, and their choices filled accordingly, based on the questions in the *pro-forma* (refer Fig. 1). The table and the graph are as follows:

STREAM	ARTS							
Ques. No./Options	1	2	2 (i)	3	4	5	6	6 (i)
a.	4	5	4	4	0	4	6	2
b.	6	3	1	4	9	1	13	2
c.	5	4	2	4	3	2		1
d.	2	5	0	6	2	7		1
e.	2	2		1	5	5		

Table 2

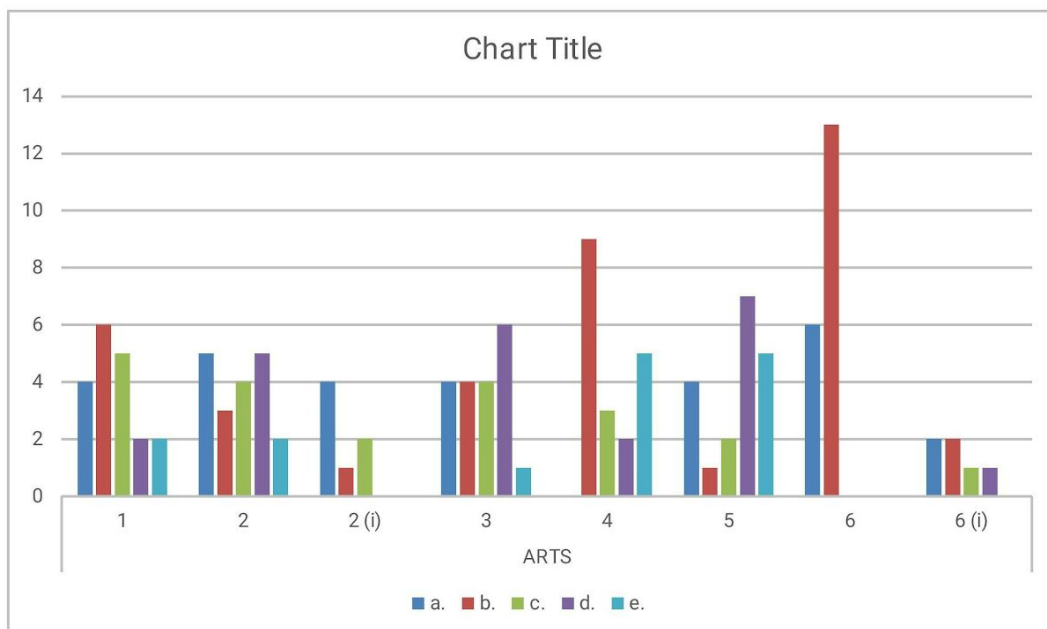

Graph 2

Observations and result: (from the graph)

- Out of the **19** students, there was a mixed response for Ques. 1 and 2 (refer Fig. 1).
- The conditions in which they felt stressed or nervous, most of them preferred to listen to music to release it out.
- Very few students feel disappointed on the day of the exam. (Q.3 - refer Fig. 1)
- When it comes to an unexpected situation like when the questions come quite different from what they expect then most of them seem to find it challenging.
- Very few feel good on the day of results, but majority seems to be nervous.
- Greater number of responses came from the students who **don't** have stage phobia. Those who have, they participate in activities to overcome the same.

Table 3 and Graph 3: Consist of the respondents from the *Commerce* stream, and their choices filled accordingly, based on the questions in the *pro-forma* (refer Fig. 1). The table and the graph are as follows:

STREAM	COMMERCE							
Ques. No./Options	1	2	2 (i)	3	4	5	6	6 (i)
a.	9	7	19	7	1	15	16	12
b.	5	5	5	9	33	4	47	3
c.	24	11	13	17	7	10		1
d.	25	22	3	29	8	24		0
e.	0	18		1	14	10		

Table 3

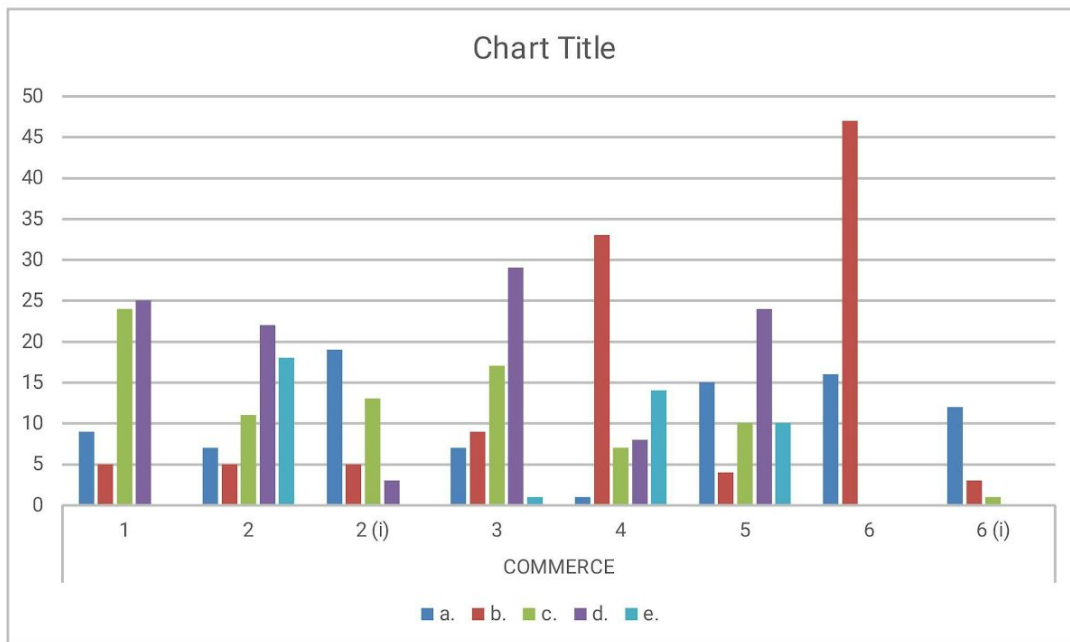

Graph 3

Observations and result: (from the graph)

- Out of **63** students, 24 of them think they don't hesitate while being asked a sudden question in the class but 25 of them are quite opposite as they seem to be nervous in such a condition. (Q.1- refer Fig. 1)
- A majority of students (40 in total) feel so nervous and stressed a day before the exam and to release it out, they prefer to listen to music or chat with friends.
- Majority seems to be nervous on the day of the exam whereas very few are excited and/or feel good.
- Most of the students find it challenging when the question paper appears different from what they expected it to be. Least seem to excited.
- Nervousness is the main issue on the day results for them.
- Those who have stage phobia are quite lesser than those who don't have, meaning mostly they're confident enough.

Table 4 and Graph 4: Consist of the respondents from the *Science* stream, and their choices filled accordingly, based on the questions in the *pro-forma* (refer Fig. 1). The table and the graph are as follows:

STREAM	SCIENCE							
Ques. No./Options	1	2	2 (i)	3	4	5	6	6 (i)
a.	13	10	54	17	3	32	69	27
b.	15	11	14	25	74	14	99	24
c.	68	23	39	42	26	21		14
d.	70	59	17	79	19	54		4
e.	2	65		5	46	47		

Table 4

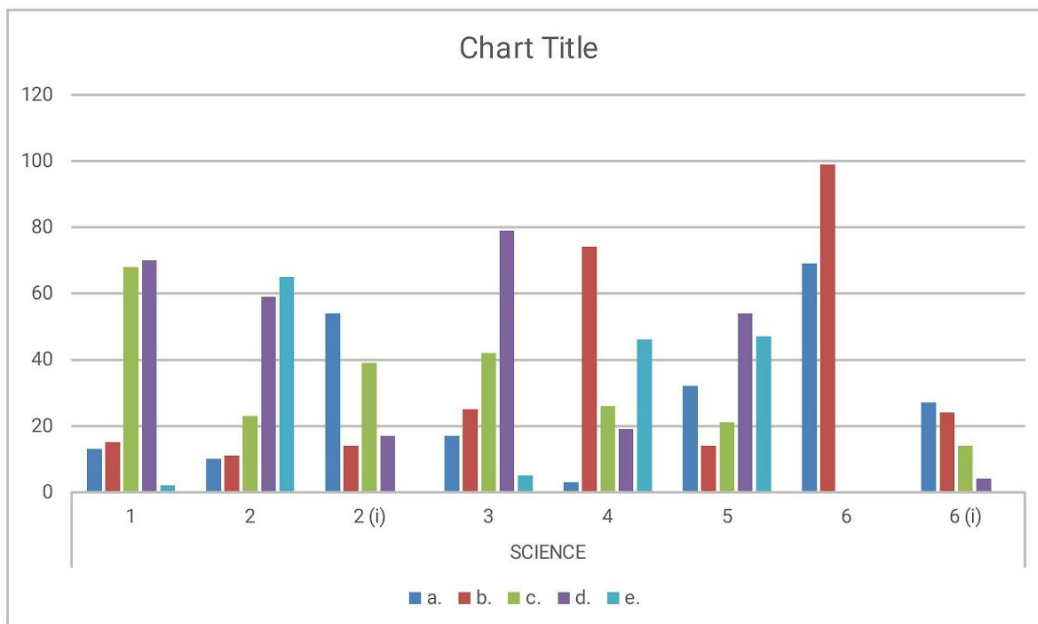

Graph 4

Observations and result: (from the graph)

- Out of **168** students, 68 find it quite normal when they're asked a sudden question in the class, but on the contrary, 70 of them feel so nervous. (Q.1- refer Fig. 1)
- Mostly they feel nervous and stressed a day before the exam. Very few seem to be excited or feel good.
- Usually they prefer to listen to music and/or chat with the friends to resolve the issue they face.
- Almost 50% of them go nervous on the day of exam. Still most of them find it normal, very few get excited. Disappointed being the least.
- Unexpected questions appearing in the papers make them challenging in the given scenario. But mostly they're disappointed as well.
- Nervousness and anxious again top the table when it comes to the situation before the release of the results.
- Majority thinks they're confident as they don't have stage phobia but still a good number of them have the issue, and to overcome the same they usually take part in activities and/or get themselves motivated by others (sources could be any).

Conclusion:

Based on the entire data collectively, some significant conclusions have been generalized : (*Fig. 1, tables and graphs* should be referred for further citations)

- Mixed responses came for both being normal and nervous when suddenly asked a question during the lecture (refer Fig. 1), comprising of 38.8% each, out of total.
- Nervousness (34.4%) and stress (34%) are the main issues faced by the students a day before exam. Very few seem to be excited and feel good. In such conditions, they prefer listening to music or chatting with friends to feel somewhat better.
- 45.6% of the total feel nervous on the day of exam, whereas hardly few feel excited (11.2%) and feel good (15.2%).
- In the situation where unexpected questions appear in the papers, almost the majority finds it challenging, on the contrary, only 1.6% seem to be excited.
- Near to 60% of the respondents get nervous (34%) and anxious (24.8%) on the day of release of the results. Least being those who feel good.
- When it came to "stage phobia," a good proportion (64.6%) said they are confident but the rest (36.4%) still face the issue. And to overcome to issue they either participate in relevant activities and/or get motivated by other means.

Recommendations:

- I would recommend that those who undergo nervousness or are usually stressed in such situations then it must be the priority for the parents/guardians as well as the teachers to figure the main reasons causing such issues, and find a solution to rectify the same.
- In most of the cases, if a student undergoes a prolonged nervousness, anxiety and stress then it may cause depression, which should properly be dealt with.
- Nowadays, many suicidal cases arise due to depression and the most common reason behind this is nothing but academics, so certain measures and steps should be taken by the institutions as well to overcome such issues.



ST. ALOYSIUS' COLLEGE

(AUTONOMOUS), JABALPUR(M.P.)

Reaccredited 'A+' Grade by NAAC (CGPA 3.68/4.00)

College with Potential for Excellence (CPE) by UGC

DST-FIST Supported & Star College Scheme by DBT.

SAMPLE PROJECT REPORTS

2019-20

FACULTY OF COMMERCE

INDEX

1. PROJECT THEME / TITLE
2. ORIGINALITY DECLARATION OF STUDENT
3. APPROVAL LETTER BY SUPERVISOR
4. CERTIFICATE OF WORK COMPLETION
BY INSTITUTION
5. ACKNOWLEDGEMENT LETTER
6. CHAPTER - I
7. CHAPTER - II
8. CHAPTER - III
9. LIST OF REFERENCES

Declaration of Student's Original Work

विद्यार्थी की मौलिकता का घोषणा पत्र

I Isha Malhotra hereby declare that this Field Project report is based on the original work done by me, in which published and unpublished material has been used after due approval. I also declare that the submitted report has not been submitted for any other degree / course in the past / present.

मैं एतद द्वारा घोषणा करती / करता हूँ कि यह परियोजना रिपोर्ट मेरे द्वारा किये गए मूल कार्य पर आधारित है, जिसमें प्रकाशित एवं अप्रकाशित सामग्री का प्रयोग विधिवत स्वीकृति के उपरान्त किया गया है। मैं यह भी घोषणा करती / करता हूँ कि प्रस्तुत रिपोर्ट किसी अन्य डिग्री / पाठ्यक्रम हेतु पूर्व / वर्तमान में प्रस्तुत नहीं किया गया है।

Name of student/ Students (छात्र / छात्रा का नाम) : Isha Malhotra
Class (कक्षा) : B.Com 1st year App. Eco.
Roll Number (अनुक्रमांक) :
Signature with date (हस्ताक्षर दिनांक सहित) : Mallhotra
4th April 2020

Work Completion Certificate



BHARAT ROLLING SHUTTER INDS

MAYANK MALHOTRA

(PROPRIETOR)

Add. - 1858/2, Katni Road, Shanti Naga,

Damoh Naka, Jabalpur (M.P.)

Contact - 8827949484

This is to certify that (name) Isha Malhotra
Class B.Com. 1 'A' of St. Aloysius College (Autonomous), Jabalpur, has
completed his/ her Field Project work by being present in this institution
from..... To and has worked/ trained in the
field of Bharat Rolling Shutter Inds.
(Name) is extremely
hardworking, dedicated and result-oriented. He / she did good / excellent work
during his/ her tenure in the organization. We wish him/her a golden future.

With best wishes

Date: 4. April 2020

Place: Jabalpur

For Bharat Rolling Shutter Industries

MAYANK

Proprietor
Authorized Signature with seal

MAYANK MALHOTRA

Name

CHAPTER-I

- INTRODUCTION AND SCOPE OF PROJECT WORK
- BACKGROUND, LITERATURE REVIEW
- PROJECT WORK PLAN, RELEVANCE AND TARGET RETURN
- DETAILS OF THE CONCERNED WORKPLACE / INSTITUTION
(WHERE THE WORK IS DONE)

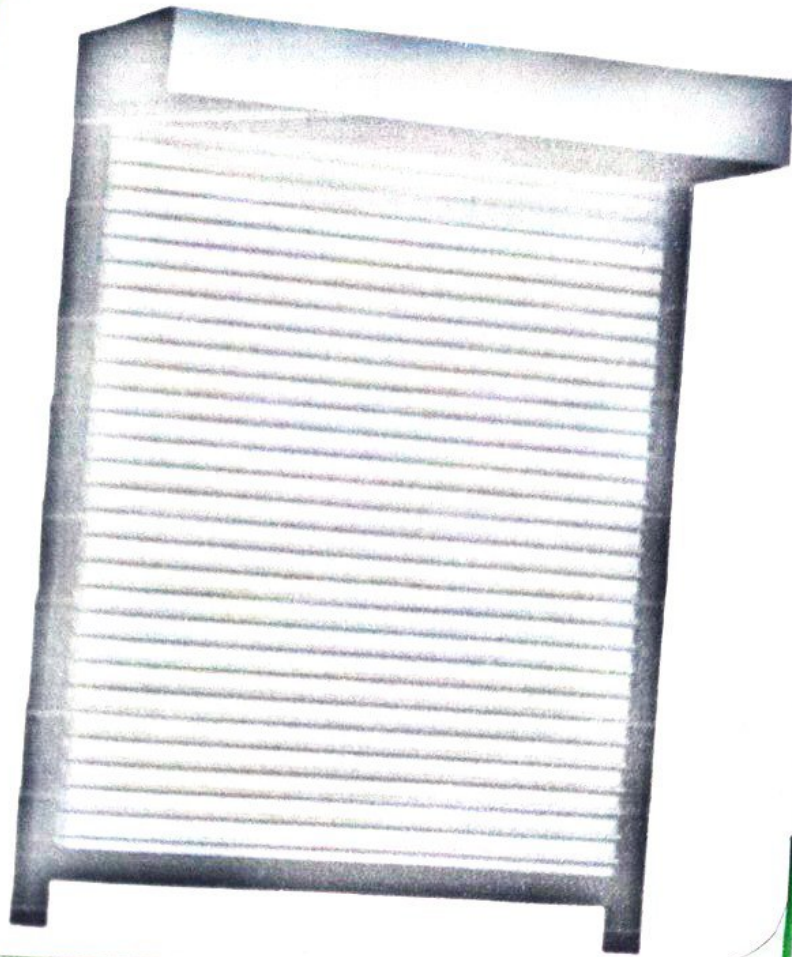

ROLLING SHUTTERS



CHAPTER - I

INTRODUCTION -

On Field report -

Field reports are often assigned in the applied sciences, where it is important to build a bridge of relevancy between the theoretical concepts learned in the classroom and practice of actually doing the work we are being taught to do.

It facilitates the development of data collection techniques and observation skills and allow us understand how theory applies to real world situations.

It is also an opportunity to obtain evidence through methods of observing professional practice that challenge or refine existing theories.

When writing a field report one need to -

- Systematically observe and accurately record the aspects of a situation.
- Continuously analyze the observations
- Keep the report's aims in mind while observing

SCOPE -

Of Field project -

A report scope enables one to create multiple instances of a report using a single report layout. Using a scope, each report instance contains data specific to an individual field value, such as a business unit or department.

Each report instance can share the same layout while containing unique data for these field values.

When defining a report, one can use the scope feature to create multiple instances of a report from a single request.

Business analytics has a wide range of applications and usages. It can be used for descriptive analysis in which data is utilized to understand past and present situations. This kind of descriptive analysis is used to assess the current market position of the company and the effectiveness of previous business decisions. It is also used for predictive analysis, which is typically used to assess previous business performance.

A manufacturing establishment is defined as a productive unit that is engaged in activities to transform a product mechanically into a product which can be used by the final user.

SCOPE -



DESIGNER SHUTTERS



SOME
COLORED
SHUTTERS

Of Rolling Shutter Industries -

A roller shutter, roller door or sectional overhead door is a type of door or window shutter consisting of many horizontal slats hinged together.

On large doors, the action may be motorized. It provides protection against wind and rain.

Roller shutters have a wide scope, including doors for vans, garages, kitchens, schools, prisons and warehouses.

In some parts of the world, roller shutters are subsidized by local governments due to the inherent security benefits.

In areas that are frequently exposed to inclement weather, these shutters are used as a method of insulation and can protect windows against hail damage.

The growing demand of product due to their long life and fire resistance property, rising adoption of product by retailers and shop owners, increasing number of infra-structural development and various construction projects by the government are the major factors fostering the growth of the market in the forecast period of 2022 to 2029.

Additionally, the increasing number of new households and increased spending on home renovation by owners also accelerates the demand for roller shutter.

Galvanized steel slats

1, silver color 2, beige color 3, natural color 4, white color



DIFFERENT COLOURS IN SLATS

LITERATURE REVIEW-

MEANING -

It is a systematic and critical analysis of the literature on a specific topic. It describes trends, quality, relationships, inconsistencies and gaps in the research; and ~~its~~ it details how the works enhance your understanding of the topic at large.

A literature review is an overview of existing literature in a particular scholarly area.

With a lit review, one will -

- Gather information about the topic, including the sources used by others who have previously conducted research.
- Find if ~~our~~ our specific research question has already been answered.
- Find out what areas or perspectives have not yet been covered by others on our topic.
- Analyze and evaluate existing information.

LITERATURE REVIEW -

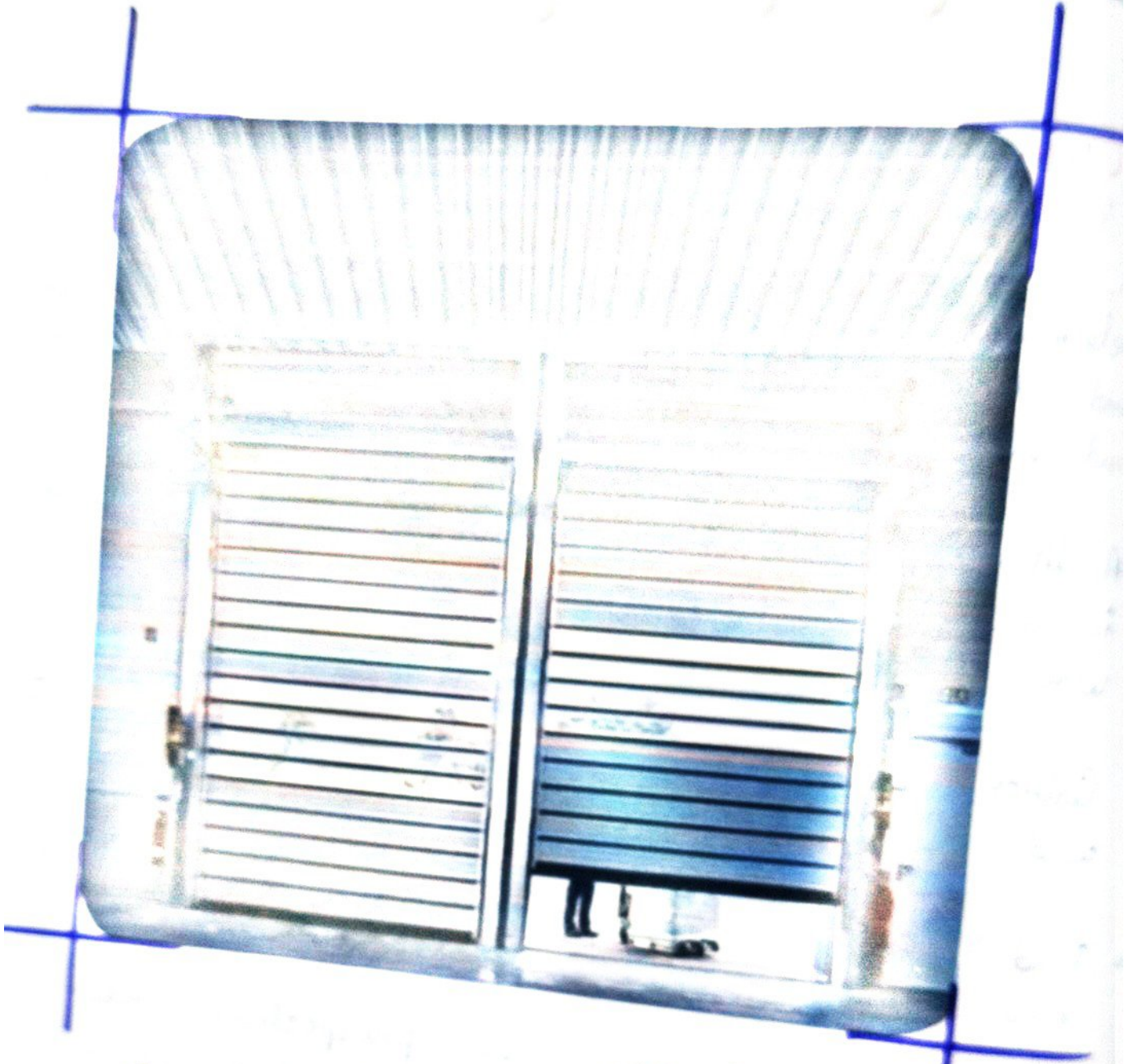

SOME CUSTOMISED MODERN SHUTTERS

• SHUTTER TYPE -

One of the methods of classification of shutter is installation position shutter.

The clear height of the shutter is called as SOFFIT LEVEL.

• COMPONENTS USED IN SHUTTER -

SLAT - It is the basic component of a shutter. The shutter curtain is formed by inter-locking of no. of slats.

PIPE - The shutter curtain rolls over the pipe while opening & closing of shutter. The pipe used should be heavy duty pipe suitable for mechanism applications.

GUIDE CHANNELS - U-shaped guide channels are used

SHAFT - The shaft runs inside the overhanging pipe which connects the assembly to brackets.

SPRING - It is used for the counter balancing the rolling shutter.

• SHUTTER DRIVE MECHANISM -

For the operation of the shutter, different mechanism is used. For large rolling shutter, the chain sprocket mechanism is used, fitted with an electric motor.

PROJECT WORK PLAN -

MEANING -

A project work plan allows one to outline the requirements of a project, project planning goals, steps a team ~~web~~ members involved in the project.

This keeps project deliverable organised in one place and helps one stay on track to reach your object

Having a work plan, can save time and prevent duplicate efforts.

Every project plan needs goals, within each goal, one is going to outline the necessary Key Action Steps.

For my project, I started my training session for **ASIAN INSTITUTE OF FAMILY MANAGED BUSINESS [AIFMB]** to know my business for more closely.

It helped me to connect with real life situations of family business in an ideal ground to learn about the realities of business in particular and life in general.

PROJECT WORK PLAN



SAFETY- FIRE RESISTANCE

... of ... loss ... to ... of ... in ...
... of ... loss ... to ... of ... in ...
... of ... loss ... to ... of ... in ...

Work-flow of project-

The study includes the shutter market trends and forecast for global shutter market through 2022 segmented by product type, fixation type, material type, operation system, application, and region.

ANALYSIS- The report offers an up-to-date analysis regarding the current competitive market scenario, latest trends challenges, and the overall market environment.

IMPACT OF COVID-19 - Market of rolling shutter growing at a steady rate until COVID-19. It has affected the market in 3 main ways: directly affect production and demand, by creating supply chain and market disruption and by its financial impact on firms and financial market.

But, after all this, the market is still trying to cope-up the problems and difficulties during the COVID-19 and are still on-going.



COMMERCIAL SHUTTERS

RELEVANCE-

Of Rolling Shutters-

The industrial rolling shutters are made of a double wall layer of aluminium which offers efficiency, functionality, and durability, and remains robust and light weight and for accessing the large door one can go for the motorized one.

SOME MAJOR BENEFITS OF THESE ROLLING SHUTTERS ARE-

COMMERCIAL USES-

- **GIVES SUNLIGHT PROTECTION-** It is the perfect replacement for curtains in blocking the sun's rays and cools lights. It will help them save money on energy.
- **HELPS IN CONTROLLING NOISE POLLUTION-** Installing overhead shutters will keep people away from the noise by blocking at least 60 to 70% of it.
- **OFFERS PRIVACY-** When passing by the house, people usually peep inside the windows. To achieve privacy, one needs to block their peeping views. One can achieve this by installing these roller shutters.

RELEVANCE -

Handwritten notes at the top of the page, partially obscured and difficult to read.



HELPS IN CONTROLLING NOISE POLLUTION -

HEIGHTED SHUTTERS - FOR BIG VEHICLES

OFFERS PRIVACY - when raised by the shutter, the window is closed, preventing noise from entering the building. This is particularly useful for big vehicles which often have large engines and can be noisy.

GIVES AESTHETIC APPEAL - It will improve aesthetic appearance of the home and increase its value.

INDUSTRIAL USES -

OFFERS SECURITY - It provides exceptional security against vehicular access and pedestrians.

AIDS IN IMPROVING SAFETY - It has the standard anti-fall safety edges and back brakes.

WEATHER PROTECTION - Since, it is highly durable, it gives major protection against extreme heat, rain, or wind.

FIRE PROTECTION - Acts as an excellent barrier against the fire spread to buildings, both externally and internally.

With so many benefits and options, every home should install roller shutters to keep themselves and their belongings safe.

TARGET RETURN-

of the project -

By the end of this report, I will be able to understand my business more closely through some of the following points -

1. MOVING FROM PRODUCT FOCUS TO CUSTOMER

When we are focused only on our own product it is known as Product Focus.

What is important is to shift the focus and start understanding the needs of the customer, this is known as Customer focus.

So, it is important to learn where our product is used, and with that what problem of the customer is solved.

2. UNDERSTANDING THE COMPETITION -

We are not the only one offering to solve problems of the customers or meeting their needs.

Competition is not only who are in the same business as ours. There are different products but as they meet the same need, they are competition to each other.

What can be done to overcome this problem -

1. Talk to senior involved in business.
2. Identify the factors that the customer will consider before making the buying decision.
3. Conduct on the competition and a note of observation.
4. Note on the indirect competition.

• DELIVERING WHAT IS PROMISED - **EXECUTION** -
It is one thing is to get a business by promising and it is another to deliver what is promised. There are many processes involved right from get order to delivering the product, and the most imp is the concept of 'TIME'.

• DELIVERING WHAT IS PROMISED - **QUALITY** -
We have learnt what offers is offering the right of product as well as Service.

1. We have to give the minimum expected quality.
2. Better quality, provided customer is ready to pay for else it will mean cost and loss of profit.
3. Service does not always cost money, it requires commitment and systems for each processes.
4. A good product & service can make customer happy
5. It gives an advantage over competition.

• How Do WE VALUE OUR PEOPLE -
When business started, people were hired only helpers. They needed clear instructions and were not expected to use their brain.
But now, they want responsibility and satisfaction of having contributed, challenges, involvement are self-driven.

DETAILS OF THE CONCERNED INSTITUTION -

Asian Institute For Family Managed Business (AIFMB)

It is a 'not for profit' company formed with the objective to catalyze the growth of Family Business Entrepreneurship in India by encouraging youngsters to learn business or to start one.

It offers a free on-line program to the students to systematically help them to learn about different aspects of business. This is a certificate course of Management Basics with a duration of 6 Hours.

While there is a need of doing something new, AIFMB promotes importance of learning from and appreciation of the tacit knowledge that the established businessmen have acquired over years of experience. The online course counts on 24 sessions consisting of a video each followed by the required discussion with a businessman for understanding practical aspects of the business.

It aims to create a significant and sustainable impact with a collaborative web model.

EXECUTION -
 The first thing is to get a business plan prepared
 and then to deliver what is promised
 there are many processes involved right from
 order to delivering the product, and the way in
 which the concept of TIME?

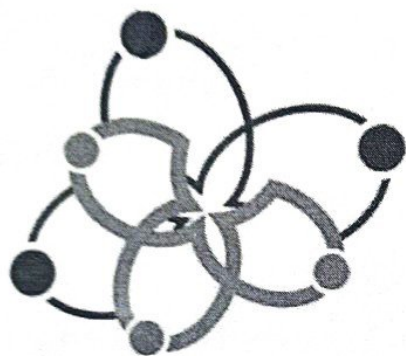

**ASIAN
 INSTITUTE OF
 FAMILY MANAGED
 BUSINESS**

**Asian Institute of Family Managed Business
 (AIFMB) for Family Managed Business
 Courses**

AIFMB

How Do We Value Our Time?
 When business started, people were hired
 and they worked clear instructions and were
 expected to use their time
 and they were responsible and they
 contributed. Challenges and
 things.

This course envisages advancement on 3 pillars of education - knowledge, skills and attitudes.

- Knowledge - Applying oneself to the family business & expose ~~to~~ one to each and aspects of the business. Whatever is our academic background, it will add to our knowledge about business tremendously.
- Skills - We will witness and eventually develop skills in areas related to communication, observation, listening, negotiation, decision making, etc.
- Attitudes - Finally one will realize values of learning to face failure, to take on challenges, to do big.
One will become alert to the values of becoming dependable, passion, perseverance, curiosity, attention to details, initiative and the most important - the role of values and ethics in family business culture.

At the same time, one will also learn about the vital role of the family values and dynamics in the family business. How family dynamics become the critical pillar and support for the business.

CHAPTER-II

PROJECT WORK FLOW-

Meaning -

A project workflow is a carefully planned seq of the tasks and activities you need to do complete a specific project.

Having a clear order of tasks in a project helps project get done more efficiently and effectively. They save time, improve results and increase collaboration.

For My Project my work flow plan is as follows,

• Conception And Initiation -

The first step is to settle on the idea of a project to scratch out the concept. Once we have an idea, we do a little research to see how it would be completed, then pitch it to the relevant power for approval.

This stage will change a lot depending on the project which is being developed.

As my topic is rolling shutters industry, first I tried to understand the concept and consulted my mentor and then discussed with the firm owner from where I am surveying.

In the conception and initiation phase, we need to enough idea of how long it will take, how it will cost, and the effect it will have.

Project definition And Planning -

Once our project has been given the go-ahead time to stamp out the scope, schedule, cost project.

This is also the stage where one wants to create RISK MANAGEMENT plan; identifying potential cost obstacles and develop procedures to prevent

For my topic, I started planning what has to done in project and then in business, start finding consequences and obstacles that can be faced in near future and ideas to deal with

Launch And Execution -

The project launch or execution phase is next, and is where things kick into overdrive. This is where begins on project.

I started my training session from AFMB to the business were closely its ups and downs how the work is executed and how its to be carried in future.

Implementation and Performance -

This step of project occurs over the time from the project's launch to its completion, and serves as a method to measure and compare the status of the project compared to the original plan.

This is a stage where I implemented my knowledge in the business that I received from my AIFM training sessions, such as understanding the product, customer's interest, market competition, etc.

Conclusion -

The final ~~or~~ of the project steps is that of conclusion. This is where, for all intents and purposes, the project has been completed and the outcome has been approved.

The major task of this section is evaluation of project. The ultimate goals of the project need to be compared with the actual outcome and assessed as to the quality, accuracy and speed at which it was achieved.

For my project, the desired outcome was satisfactory, as all the purpose for the project was accomplished, i.e., that was to know the business and its future goals.

DETAILS OF INFORMATION COLLECTION / FIELD SURVEY

Questionnaire -

A questionnaire is a research instrument consisting of a series of questions for the purpose of gathering information from respondents through survey or statistical study.

Some of the questions, I asked from my concern field survey are as follows -

1. How do you handle your business -

a. Solely

b. Partnership

2. How many days does it take to complete one order

a. Around 1 week

b. According to order

3. Do you supply your products to other states -

a. Yes

b. No.

8578 2204448804721

Mob. 8827949484

BHARAT ROLLING SHUTTER INDS.

Manufacturer - Manual & Automated Rolling Shutter

EURO
ANTI-THEFT ENGINE



SOME PICTURES FROM THE FIELD



[Faint handwritten notes on the left side of the page]

[Faint handwritten notes on the right side of the page]

DETAILS OF PERFORMANCE



COLLEGE
A question
of the
industry
is possible

of the
industry

of the
industry

of the
industry

of the
industry

of the
industry

Field

METHODS OF ANALYSIS

Meaning -

Data analysis is the process of collecting, model and analysing data to extract insights that aid decision-making.

Businesses today need every edge and advantage can get.

Why is Analysis Important -

- Better Customer Targeting - It helps businesses to see where they should be focusing their efforts, than wasting precious time, resources, money,
- Better Problem-Solving Methods - Informed decisions more likely to be successful decisions and this businesses make right choices and avoid costly pitfall
- Reduce Operational Costs - It shows which areas use more resources and money, and which areas not producing and these should be scaled or eliminated outright.
- More accurate data - It helps businesses acquire relevant, accurate information suitable for develop future.

Some of the important analysis methods are -

● Qualitative vs. quantitative -

Qualitative means to measure something by its quality we are exploring how we describe something. In this, we work with descriptions, thoughts, perceptions and try to understand behaviour.

Quantitative means to measure by its quantity, we explore facts, numbers and percentages. We work with statistics, formulae, etc.

For the project - for project, I used qualitative analysis, as it is more easy to understand and analyse the information.

● Primary vs. Secondary -

Primary data refers to the first hand data gathered by the researcher itself. It is a real time data. It requires surveys, observations, questionnaires, etc. It takes very long time.

Secondary data means data collected by someone earlier. It is a past data.

It requires publications, books, records, etc. It is done in short period.

For the project - I used primary data, as through I got to know the business more closely, and is more specific, and accurate.

Descriptive Vs. Experimental -

Descriptive is a method to describe the demographics of the research variables. The demographics being 'why, what, when, how'. It is mostly observational.

Experimental is a scientific approach of dealing with 2 or more variables. It is basically an experiment conducted to bring out the cause-effect relationship.

For the project - I choose, descriptive, as it is more briefly explained and effective.

ANALYSIS OF INFORMATION / DATA

DATA ANALYSIS -

It is a process of inspecting, cleansing, transforming, and modelling data with the goal of discovering useful information, informing conclusions, and supporting decision-making.

Data analysis has multiple facets and approaches, encompassing diverse techniques under a variety of names and is used in different businesses, science, and social science domains.

In today's business world, data analysis plays a role in making decisions more scientific and helping businesses operate more effectively.

Types of Data Analysis: Techniques and Methods

- Text Analysis
- Statistical Analysis
- Diagnostic Analysis
- Predictive Analysis
- Prescriptive Analysis

1 AMROFINI DE 212YJAI
ATAAD

Parts Overview

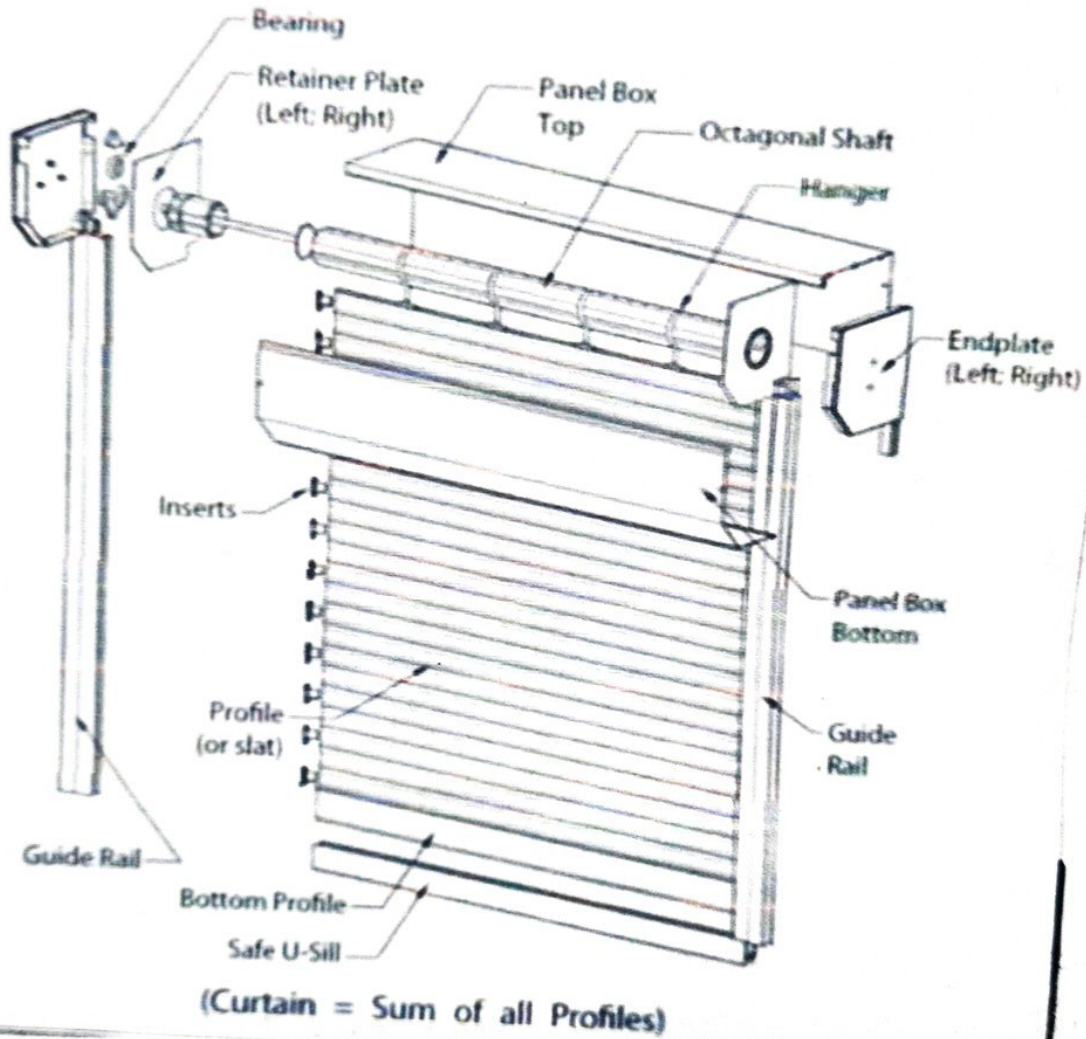

PARTS OVERVIEW OF
ROLLING SHUTTER

Analysis of Rolling Shutter Industry -

The roller shutter market is expected to gain a growth in the forecast period of 2023 to 2029. The growing demand is due to their long life fire resistance property.

The technological advancement such as automation reduced weight generate growth opportunities in the long run. The slowdown in supply chain due to COVID-19 pose as a challenge for the market.

This roller shutter market provide details of recent developments, trade regulations, import export production analysis, etc.

The global roller shutter market is segmented ~~bas~~ ~~market~~ by product type, material, etc.

Based on this, the market can be categorized built on roller shutter, built in roller shutter, integrated roller shutter and with fitted laths.

The built in roller shutter segment is expected dominate the market during the forecast pe on account of their widespread uses in kitchen, garage, schools, warehouses, etc.

CHAPTER-III

• CONCLUSIONS, RETURNS AND

ANALYSIS

• CHALLENGES IN PROJECT WORK

• RECOMMENDATIONS BASED ON

THE FINDINGS

CHAPTER-III

CONCLUSIONS-

Meaning Of Conclusion-

A conclusion is the final piece of writing in a research paper, essay or article that summarizes the entire work.

Summarize the key supporting ideas one discussed throughout the work, offer one's final impression on the central idea.

Purpose-

The purpose is to wrap up the writing and reinforce the main idea that is presented in the body of project.

CONCLUSION OF MY PROJECT-

The report covers comprehensive data on emerging trend market drivers, growth opportunities, and restraints that can change the market dynamics of the industry.

It provides an in-depth analysis of the market segments which include products, applications, and competitor analysis.

ANALYSIS

What does Analysis mean -

It is a professional discipline of identifying business needs and determining solutions to business problems. Solutions include a software-systems development component, but may also consist of process improvements, organisational change or strategic planning and development.

Although there are different role definitions dependent upon the organisation, there does seem to be an area of common ground where most business analysts

SWOT Analysis of Industry -

The purpose of a SWOT analysis of the industry is to identify the key factors that affect the success of the industry.

The 4 factors of analysis are - strengths, weaknesses, opportunities and threats.

Strengths -

The strengths of the industry are that it is relatively stable. Although the demand for manufacturing tends to fluctuate with the ups and downs of the economy, it is characterised by regular periods of recovery following any downturns.

- Data collection - one of the major challenge is having to enough data. Another challenge is deciding best data collection tool or procedure to solicit for data.

Some challenges faced by Industry -

- Wastage of material - Waste is a regrettable but an element of any process of manufacturing. To avoid financial losses, prevent high overhead, overall efficiency and the material wasted.
- Shortage of Skilled labor - Although automation can help the labor gap, humans will still be required. Industries are suffering from staff shortfall.
- ~~Env~~ Environmental Consciousness - Customers are more concerned nowadays. Industries who work with chemical and loud noise machinery, must be aware of environmental impact of their materials.

RECOMMENDATIONS BASED ON THE FINDINGS

The future of Industries -

The changing economics of production and distribution along with shifts in consumer demand and the e of "smart" products, are pushing manufacturers to explore rapidly new ways of creating and capturing

As technology continues to advance exponentially, bars to entry, commercialization, and learning are eroding.

The boundary separating product makers from product sellers is increasingly permeable.

Manufacturers are feeling the pressure - and gaining ability - to increase both speed to market and customer engagement.

At last, I would like to conclude by saying that, there is a lot of scope in these business if one has proper knowledge and access to the business.



ST. ALOYSIUS' COLLEGE

(AUTONOMOUS), JABALPUR(M.P.)

Reaccredited 'A+' Grade by NAAC (CGPA 3.68/4.00)

College with Potential for Excellence (CPE) by UGC

DST-FIST Supported & Star College Scheme by DBT.

SAMPLE PROJECT REPORTS

2019-20

FACULTY OF MANAGEMENT

ST. ALOYSIUS' COLLEGE JABALPUR

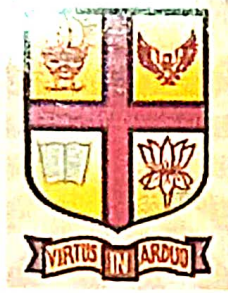

(Autonomous)

Reaccredited at 'A+' level by NAAC,
College with potential for excellence by UGC

SESSION :2019-20

Major Project Report

On

COMPARISON BETWEEN MUTUAL FUND AND STOCK MARKET INVESTMENT

(A)

Sakshi Chakrawarty

Submitted to

Dr. Shraddha Shrivastava

Submitted by

Sakshi Chakrawarty

B.B.A 3rd Year

Admission No. 46779

Certificate

This is to certify that the Project Report entitled " **COMPARISON BETWEEN MUTUAL FUND AND STOCK MARKET INVESTMENT** " which is being submitted here for the award of degree of Bachelor of Business Administration, Jabalpur by **Sakshi Chakrawarty** of BBA 3rd Year is done under our supervision and guide.

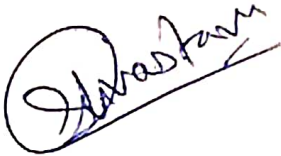

Dr. Shraddha Shrivastava

Assistant Professor

Department of Management



Dr. Rashmi A. Patras

Head of the Department

Department of Management



Declaration

I SAKSHI CHAKRAWARTY do hereby declare that the project report submitted to the St. Aloysius College (Autonomous) Jabalpur (M.P.) in partial fulfillment for the award of degree in Bachelors of Business Administration entitled "**COMPARISON BETWEEN MUTUAL FUND AND STOCK MARKET INVESTMENT**" is an original piece of major project work carried out by me under the guidance and supervision of **Dr. Shraddha Shrivastava**.

I further declare that the information has been collected from genuine and authentic sources and I have not submitted this project report to this or any other university for the award of degree of examination.

Date:

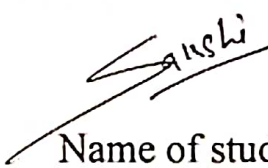
Name of student

Sakshi Chakrawarty

Acknowledgement

I would like to express my sincere gratitude to the Head of the Department **Dr. Rashmi A. Partas** for giving the opportunity.

I would also like to propose a sense of gratitude to my supervisor **Dr. Shraddha Shrivastava** for her constant guidance and supervision. I would like to appreciate her keen observation and dedication.

I am really thankful to my parents who stood beside me for every support.

Date:

Name of student

Sakshi Chakrawarty

INDEX

Chapter - 1

Introduction

1 - 19

Chapter - 2

Review of Literature

20 - 26

Chapter - 3

Research Methodology

27 - 41

Chapter - 4

Data Analysis & Interpretation

42 - 50

Chapter - 5

Conclusion & Reference

51 - 53

STOCK EXCHANGES IN INDIA

Stock Exchange (also known as stock market or share market) is one of the main integral part of capital market in India. It plays a vital role in growing industries and commerce of a country which eventually affect the economy. It is well organized market for purchase and sale of corporate and other securities which facilitates companies to raise capital by pooling funds from different investors as well as act as an investment intermediary for investors. Moreover, it ensures that securities should be traded according to some pre defined rules and regulations.

London Stock Exchange is the oldest stock exchange in the world whereas Bombay Stock Exchange is the oldest one in India.

In India, there are 7 stock exchanges out of which NSE and BSE are two main indices. Most of the trading in India stock market takes place on these two stock exchange. Both the exchanges follow the same trading hours, trading mechanism, settlement

of more than US\$ 1.65 trillion as on 31 January 2015 (Monthly Reports, world Federation of Exchanges) Moreover, it was the first exchange to provide fully automated screen based electronic trading system. Nifty is the indices to measure overall performance of the National Stock Exchange which comprises of 50 stock index.

Functions of Stock Exchange

The Stock Exchange serves two critical functions :

- It provides a critical link between companies that need funds to set up new business or to expand their current operations and interested investors.
- Stock Exchanges also act as a guide for the investors that have excess funds to invest in such companies.

The main aim of this study is to determine the impact of various economic variables on the performance of stock of selected listed IT companies on NSE

Board of India (SEBI) has prescribed certain limits on expenses that could be charged to each individual scheme. Further, investors tend to benefit from professional fund management at relatively lower costs by investing in mutual fund schemes.

Total expenses charged by the fund to the scheme are denoted by the total expense ratio (TER), expressed as a percentage of total AUM (Assets under management). With ceiling limits of TER prescribed by SEBI for different scheme categories, investors can avail of professional fund management services for their investments by investing in mutual funds.

Mutual funds are also fast emerging as a preferred option for meeting an individual's financial goals according to each individual's choice of investment horizon and risk appetite. The investors can invest in different mutual fund schemes by submitting the application form physically at the official points of acceptance or through the website/mobile app of the mutual fund house, or other digital options.

provided by Registrar & Transfer Agents, etc.

Categories Of mutual fund Schemes

Open for the investors to

Choose from :

1. **Equity Funds** - Such funds must invest at least 65% of their net assets in equity shares and equity-related instruments. Within the umbrella of equity funds, there are several sub-categories depending upon the investment objectives and type of the scheme, such as large-cap funds, value funds, flexi-cap funds, dividend yield funds, etc.

2. **Debt funds** - Such funds must invest at least 65% of their assets in debt and money market securities. There might be further restrictions on the funds' investment pattern as per their investment objective and sub-category of such schemes within the broader category of debt funds. Furthermore, sub-categories under debt funds that investors can choose based on the

individual's investment horizon and risk appetite are overnight fund, liquid fund, short-duration fund, medium duration fund, gilt fund, credit risk fund, etc.

3. Hybrid Schemes -

Such schemes offer a combination of asset classes within the investment portfolio. As such, mutual fund schemes may invest in two or more asset classes. The investment pattern is further defined by the sub-category of **hybrid schemes**, such as aggressive hybrid fund, conservative hybrid fund, multi-asset fund, dynamic asset allocation fund, etc.

4. Solution-Oriented Schemes -

Such schemes are aimed at offering mutual fund schemes aimed at specific financial goals. At present, two types of **solution-oriented schemes** can be offered, viz. Retirement fund and children's fund. Such schemes also carry a lock-in period of at least 5 years or till the age of retirement / child attaining majority.

whichever is earlier.

5. Other Schemes -

Such schemes include index funds ETFs (exchange Traded funds), fund of Funds investing in domestic / overseas securities.

MUTUAL FUNDS VS STOCKS

Mutual fund and stock (or shares) are two very distinct financial products that are often misconstrued as identical. You may have asked what is more suitable for you? A mutual fund investment or a share market investment. This is one of the biggest dilemmas several investors face when embarking on their investment journey.

Let's understand these two unique financial products in detail to decide which is ideal for you.

Stocks are a representation of the total share capital of the company that are traded over the share market. This means that if you are a shareholder, you own a stake in the company.

When companies go public to garner funds for their business, they can receive the same in two ways:

1. They can borrow from a financial institution or raise debt, or;

2 They can raise capital from the general public.

On the other hand, mutual funds are a collection of different securities such as money market instruments (participatory notes, treasury bills, etc.), debt instruments (government bonds, corporate bonds, etc.), equities (stock), etc. It is an investment vehicle that pools the money of various investors and invests it in these securities.

Thus, mutual fund investments are a form of investment into various financial instruments that are managed by an Asset Management Company (AMC) or a fund house. On the other hand, when you invest in stock or shares, you are directly handling the buying and selling of the financial instrument. Hence, it is a more active form of investment as compared to mutual funds, which are passive. However, mutual funds being run by a fund manager are actively managed.

In simple words, shares constitute a part of a business, whereas mutual funds are a cumulative investment vehicle that invest in shares, among other asset classes. Before you try to figure out the

the ideal investment avenue for you, let's understand the difference between mutual funds and shares.

Mutual Funds vs. Stocks : Which is Better Investment ?

1. Professional Management

Leveraging the expertise and knowledge of a mutual fund expert to us one of the primary reasons why individuals consider investing in mutual funds. Investment in shares without prior experience or knowledge about the working of the financial markets can be quite disastrous. It could even easily drain your capital. Hence, experts often advise those new to the investing world to invest in mutual funds via a fund manager.

2. Save tax on mutual fund

When it comes to ELSS mutual funds, section 80C of the income tax act 1961, offers tax deduction on investment up to Rs 1.5 lakh towards such schemes. Individuals and HUF can use this deduction to reduce their tax

On mutual fund investment

3. Disciplined Investment

Another major advantage of investing in mutual funds is financial discipline, which you get to learn by investing through the SIP (Systematic Investment Plan). In a SIP, the investor is required to invest a fixed amount periodically. This automated form of investing in a mutual fund requires an individual to decide the quantum of payment and the frequency of the investment at the start of the SIP investment tenure.

4. Cost of Investing

Unlike stocks, which you can buy individually, actively managed mutual funds demand a small fee to be paid to the fund manager(s). However, one often forgets the concept of 'economies of scale' that tips their weight in the favour of mutual funds. Active management of funds surely requires extra capital from the investor's pockets, but due to their large size, mutual funds only ask a insignificant fraction of the brokerage charge from an individual shareholder.

5. Investment Horizon

Mutual fund investments often require a tenure of 5-7 years or more to generate considerable return. This is because these investment vehicles have a long-term growth trajectory. On the other hand, investing in stock can fetch you quick and substantial return if you choose the right stocks and time the buying and selling part correctly.

Whether you decide to invest in mutual funds or stocks entirely depends on your knowledge and expertise of the market and the amount of time and effort you are willing to spare. Mutual funds can prove to be a great investment instrument if you are an amateur and aim for steady return.

Comparative Table

Basis for comparison	Stocks	Mutual Funds
Meaning	Bunch of shares held by an investor indicating ownership in a corporation	The fund is operated by an AMC (Asset management company) pooling fund from investors and investing in a portfolio of assets.
Ownership	Share of a company	Share of a fund

Final Investment	Directly in the stock market	In the fund through which investment is directed
Management	Investor	Fund Manager
Risk	High	Relatively low due to professional management
Value Determination	Price of share on the exchange	NAV (Net Asset Value)
Trading	Throughout the day, at the prevailing price	Only once generally at the end of the day
Commission	paid when a stock is traded	There can be in the form of load or no-load

RELATIONSHIP BETWEEN STOCK

MARKET RETURNS

& MUTUAL FUND FLOW

The economic activity in mutual funds has been gradually increasing all over the world in the recent past. In India, mutual fund assets under management (AUMs) are also growing rapidly during these times. The phenomenal growth in the number of funds and schemes, a marked increase in the number of fund folios, and historic rise in the volume of trades by the fund industry in India. But, the investments in this private investment vehicle are still believed to be dependent on the past performance of the fund.

and current movements in the stock market. The is positively asserted that any 'bull phase' in the stock market will lead to an increase in AUMs of the mutual funds and any 'bear phase' in the share market will correspond to fall in AUMs in the mutual fund industry. Moreover, the relationship between stock market return and mutual fund flows is of high importance to all the stakeholders, including the investors, asset management companies and the researchers. Therefore, it is imperative to examine the association between the share market returns and the flow of investments in the mutual funds to explore whether the stock market return influence the flow of funds in the mutual funds in the emerging market economy of India.

There have been divergent and mixed outcomes of the several studies in this area as some of the past studies have

Confirmed the presence of the relationship whereas some other researches have concluded the absence of any such relationship. Again, some research outcomes have established both ways causal relationships, whereas some of the studies could validate the unidirectional causal relationship only. Therefore, the present paper focuses on answering the presence of this relationship in an alternative stock market, i.e., the emerging Indian stock market.

Review

Of

Literature

RELEVANT LITERATURE

◆ Warther (1995) pointed out that micro-level relationship is fundamentally different from macro level relationship. Investors often moved money from one mutual fund to another. However, not all the mutual fund movements represented changes in aggregate mutual fund flows. Some inflows were at the expense of the outflows of another mutual fund. As a result, the micro-level studies focused on how fund managers competed against each other for business. However, at macro-level, flows among mutual funds were offsetting. Only the aggregate flows into (or out of) all mutual funds were relevant. Therefore, macro-level studies focus on whether aggregate mutual fund flows will affect stock market return or vice versa.

◆ Warther (1995) examined the dynamic relationship between aggregate mutual fund flows and security return in U.S. by using weekly and monthly data for the period from Jan. 1984 to June 1993. Flows were

decomposed into expected and unexpected components by Warther. Unexpected flows were defined as the residual from the expected flow regression. Result of Warther (1995) suggested that unexpected aggregate mutual fund flows were positively associated with the contemporaneous stock market return. In addition, in terms of the lead-lag relationship, there was evidence of a positive relationship between aggregate mutual fund flows and subsequent stock market return in weekly data, and a negative relationship between stock market return and subsequent flows in monthly data.

◆ Rather than just identify the relationship between fund flows and market returns, Fortune (1998) explored the causality between flows and return in U.S. by conducting an unrestricted VAR model, using monthly data for the period January 1984 - December 1996. Empirical findings in Fortune's study were opposite to those earlier studies mentioned above.

Fortune found some evidence for feedback trading and concluded that equity fund flows were affected by only contemporaneous stock returns rather than the lagged stock returns.

◆ Edwards and Zhang (1998) examined the causal relationship between fund flows and market returns in U.S. from January 1961 to Feb 1996, by using Granger Causality model. Results of this paper suggested that only market returns would granger cause aggregate equity mutual fund flows but not the opposite.

Similar to Warther (1995), Remolona et al. (1997) also divided mutual fund flows into expected and unexpected components. However, as an additional contribution they improved the model by using instrumental variables rather than Ordinary Least Squares (OLS) regression to examine the relationship between flows and return, in an attempt to correct for possible endogeneity between returns and fund flows were not affected by either contemporaneous or lagged stock returns. Their study concluded that the short-term effect of market returns on mutual fund flows was too weak to sustain a spiral.

Edelen and Warner (2001) found a strong positive contemporaneous relationship between aggregate mutual fund flows and stock market return in daily frequency. They also suggested a positive association between stock market return and subsequent aggregate mutual fund flows. However, their findings showed that there was no statistically significant aggregate mutual fund flows

and subsequent stock market returns.

◆ Contrary to Edelen and Warner (2001), who found that aggregate mutual fund flows were negatively serially autocorrelated, Grootman and Mall (2003) found that aggregate mutual fund flows were positively autocorrelated.

Research

Methodology

RESEARCH METHODOLOGY

Research methodology is a way of explaining how a researcher intends to carry out their research. It's a logical, systematic plan to resolve a research problem. A methodology details a researcher's approach to the research to ensure reliable valid results that address their aims and objectives. It encompasses what data they're going to collect and where from, as well as how it's being collected and analyzed.

Types of Design

TYPES OF RESEARCH

DESIGN

Quantitative Research design

Quantitative research design aims at finding answers to who, what, where, how, and when through the course of research. Moreover, the outcome of the quantitative analysis is easy to represent in the form of statistics, graphs, charts, and numbers.

Qualitative Research design

Qualitative research design focuses on finding answers to how and why. It uses open-ended questions and helps the subjects express their views clearly.

Qualitative research is ideal for businesses that aim to understand customers'

behaviours and requirements

Experimental design

This type of research design looks at a problem scientifically by establishing a clear cause and effect of every event. It also tries to understand the impact of the independent variable on the dependable variable.

Often social sciences use it to observe human behaviours and understand the social psychology of human being better.

Correlational design

Correlation research design establishes a relationship between two related variables. The research observe the variables over time and then draws conclusions based on them.

This type of research design requires two different groups.

A correlation coefficient determines the

two variables and -1 means a negative relationship.

Descriptive design

Descriptive design is a theory-based research method describing the researcher's primary subject matter. This type of research design uses data collection techniques like natural observation, case studies, and surveys to derive results. This type of research design provides insight into the why and how of research.

Diagnostic design

In diagnostic research, the design strives to explore the reason behind an issue and find solutions to solve it. This type of research design tries to solve the problems in a structured form divided into the three phases - the issue's inception, diagnosis of the issue, and solution for the issue.

Explanatory design

In this research design, the researcher explores concepts and ideas on a subject to explore more theories. The main aim of the research is to explore the subject's 'undiscovered' aspects and answer questions like what, how and why.

Objective

Of

Study

Objective Of Study

Stocks represent shares in individual companies while mutual funds can include hundreds - or even thousands of stocks, bonds or other assets.

You don't have to choose one or the other, though. Mutual funds and stocks can both be used in a portfolio to help you grow your wealth and meet your financial goals.

Statement

of

Problems

Problems

- The investing landscape has been vastly transformed so that there are many unique challenges that modern investors face.
- Perhaps the most daunting challenge that modern investors face is that the sheer speed and volume of information.
- With time, many investors learn to filter out information and create a select pool of reliable source that match their investing tastes.
- Even if you have a good handle on quality information, you can still get burned when inaccurate information or basic uncertainty hits the market.
- Advertising can sometimes push an investor toward an edge by hyping an investment that isn't necessarily the best fit.

Data

Collection

Data Collection

Before we define what is data collection, it's essential to ask the question "What is data?" The abridged answer is, data is various kinds of information formatted in a particular way. Therefore, data collection is the process of gathering, measuring and analyzing accurate data from a variety of relevant sources to find the answers to research problems, answer questions, evaluate outcomes, and forecast trends and probabilities.

Our society is highly dependent on data, which underscores the importance of collecting it.

Accurate data collection is necessary to make informed business decisions, ensure quality assurance, and keep research integrity.

During data collection, the researchers must identify the data types, the sources of data, and what methods are being used.

METHODS OF DATA COLLECTION

Primary

Secondary

Primary

As the name implies, this is original, first-hand data collected by the researchers. The process is the initial information gathering step, performed before anyone carries out any further or related research. Primary data results are highly accurate provided the researcher collects the information. However, there's a downside, as first-hand research is potentially time-consuming and expensive.

Secondary

Secondary data is second-hand data collected by other parties and already having undergone statistical analysis. This data is either information

that The researcher has talked other people to collect or information the researcher has looked up. Simply put, it's second-hand information. Although it's easier and cheaper to obtain than primary information, secondary information raises concerns regarding accuracy and authenticity. Quantitative data makes up a majority of secondary data.

In this project I have collected the primary data which is as follows -

Data

Analysis

&

Interpretation

TABLE 1

1. how much do you save ? (% of annual income)

particular	in percentage %	respondent
below 5%	30%	30
10%-15%	27%	12
15%-20%	20%	10
20%and above	23.30%	8
Total		60

in percentage and respondent

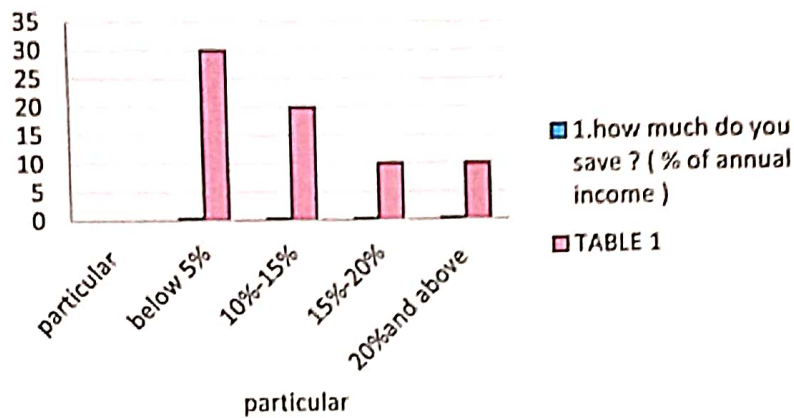

INTERPRETATION

Total No. of respondent are 60. In which the highest no. of responses are below 5% 30 / 10% - 15% 12 / 15% - 20% 10 / 20% and above 8

2. In which you like to invest ?

TABLE 2

particular	in percent%	respondent
Mutual fund	46.70%	20
Stock fund Market	53.30%	40
Total		60

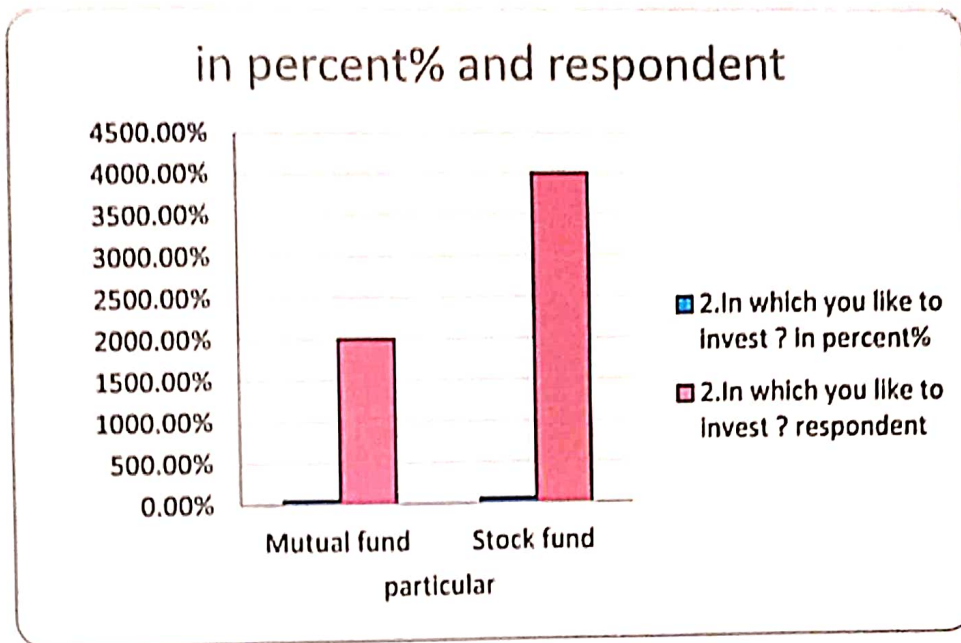

INTERPRETATION

Total No. of respondent are 60. In which the highest no. of responses are stock market [40] / Mutual fund [20]

TABLE 3

3. Which you feel more risky ?

particular	in percentage%	respondent
Mutual fund	21.70%	40
Stock market	78.30%	20
Total		60

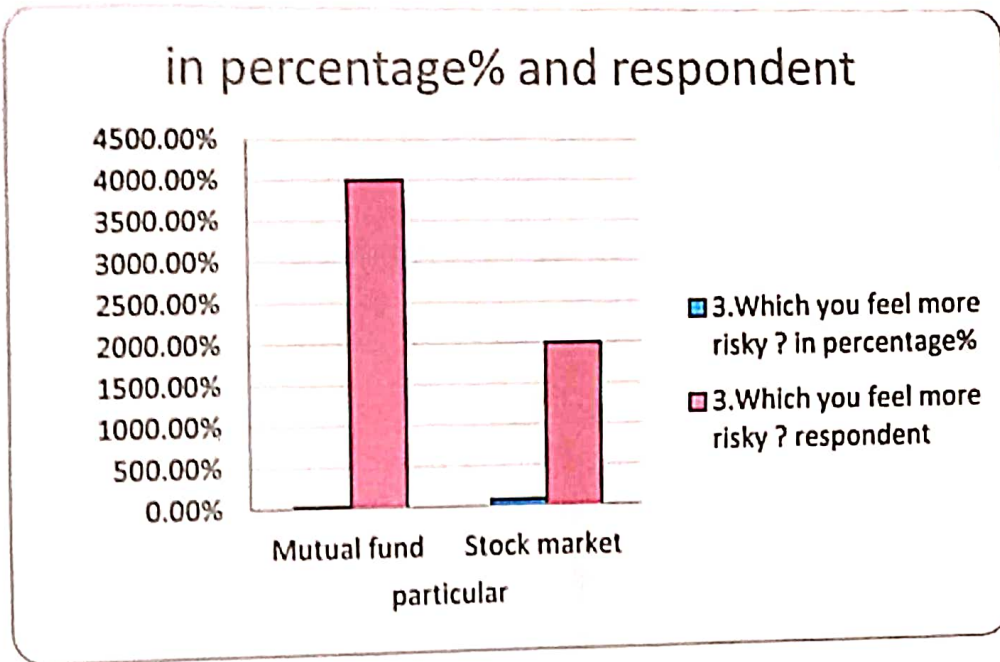

INTERPRETATION

Total No. of respondent are 60. In which the highest no. of responses are stock market [40] / Mutual fund [20]

4. What is your opinion which will give you high rate of return ?

TABLE 4

Particular	in percentage %	respondent
Mutual fund	26.70%	10
Stock market	73.30%	50
Total		60

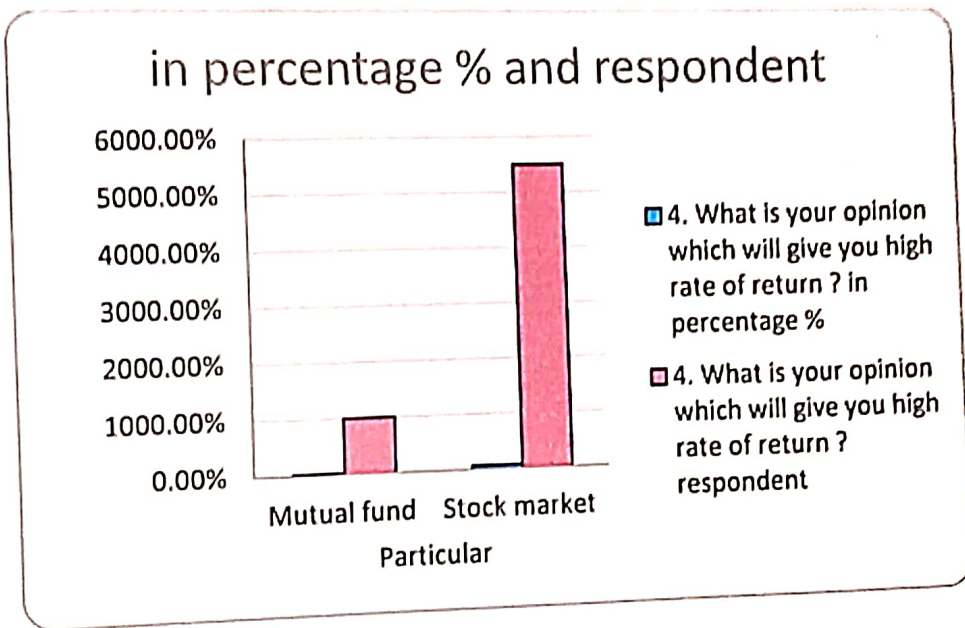

INTERPRETATION

Total No. of respondent are 60. In which the highest no. of responses are stock market (50) / Mutual fund (10).

TABLE 5

5. How much you invest in mutual funds? (% of total investment)

particular	in percentage %	respondent
below 25%	64.90%	50
25%-50%	21.10%	10
50%-75%	-	
75%-100%	-	
Total		60

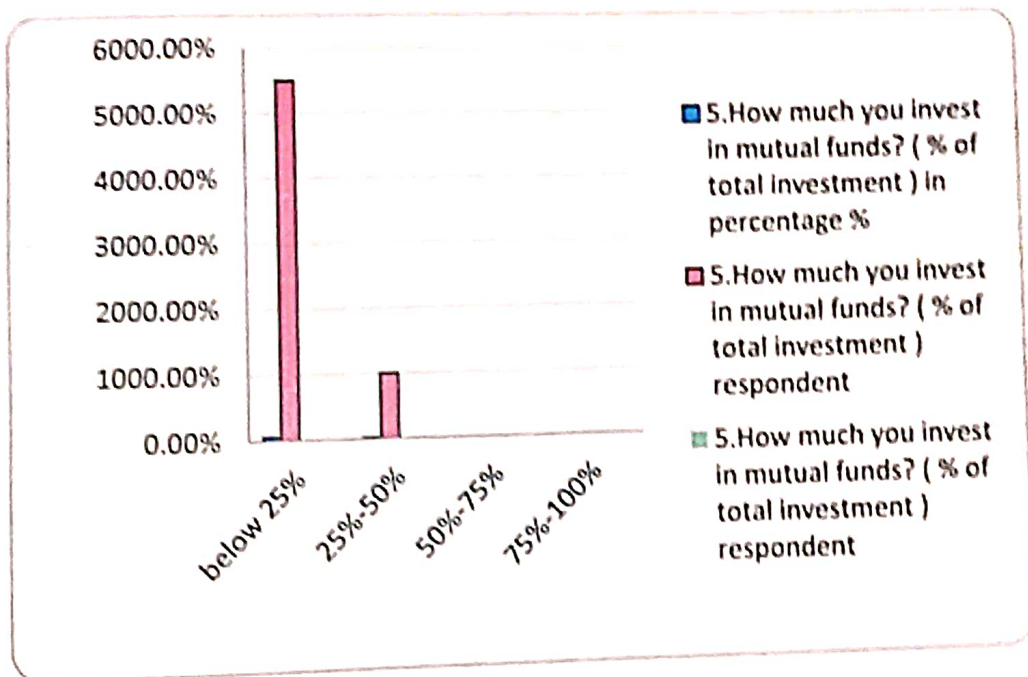

INTERPRETATION

total no. of respondent are 60. In which the highest no. of responses are below 25% [50] / 25%-50% [10] / 50%-75% [0] / 75%-100% [0]

6. How much you invest in stock market ? (% of total investment)

TABLE 6

particular	in percentage%	respondent
below 25%	47.50%	45
25%-50%	30.50%	10
50%-75%	16.90%	5
75%-100%	-	-
Total		60

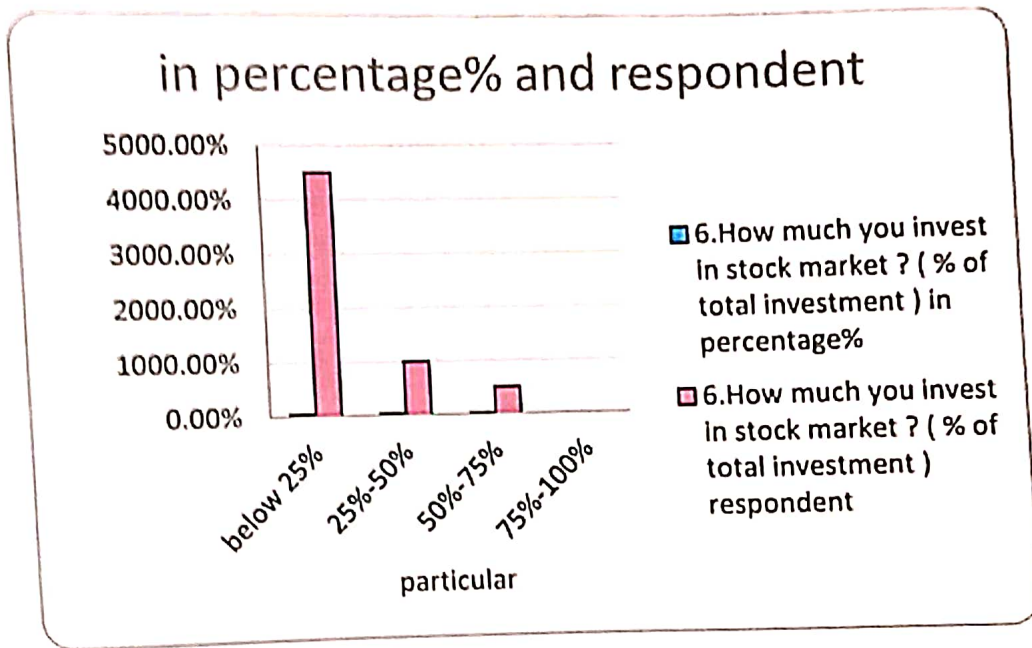

INTERPRETATION

Total no. of respondent are 60. In which the highest no. of responses are below 25% [45] / 25-50% [10] / 50%-75% [5] / 75%-100% [0].

7. How long do you preferred to invest in mutual fund ?

TABLE 7

particular	in percentage	respondent
less than 3 years	33.30%	30
3-5 years	26.30%	10
5-10 years	21.10%	5
10-15 years	14%	15
15 years and above	-	-
Total		60

in percentage and respondent

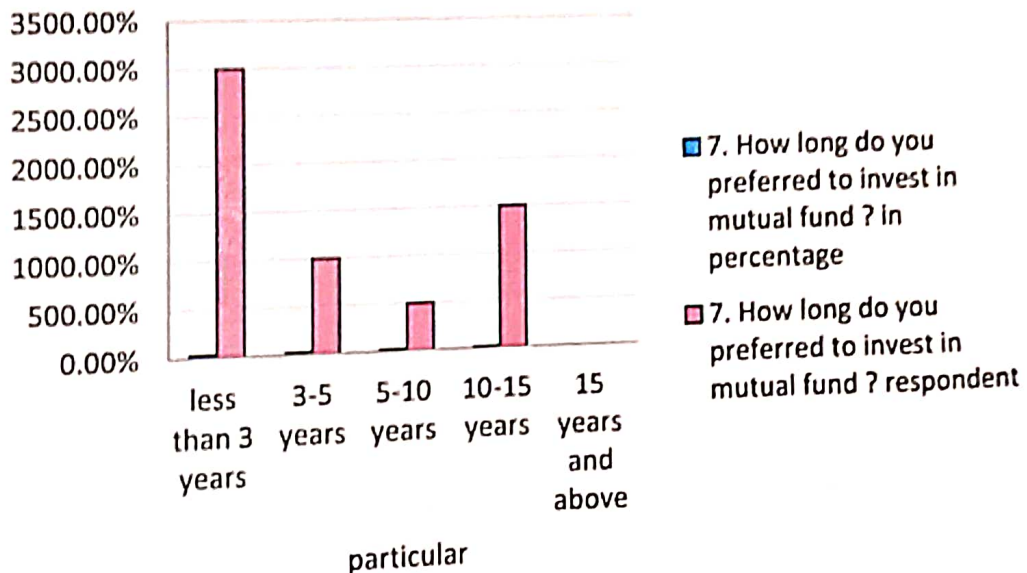

INTERPRETATION

Total no. of respondent are 60. In which highest no. of response are less than 3 years [30] / 3-5 years [10] / 5-10 years [5] / 10-15 years [15] / 15 years and above [0]

Conclusion

&

References

CONCLUSION

In this research paper, the existence of the presence of the comparison between Mutual fund and stock market investment in India is assessed by using the multiple regression analysis. From the study, we can conclude there is no significant relation between AVMs and stock market returns. Also, stock market returns are not the sole factor to adequately explain the changes in AVMs of different mutual funds over the period of the study. Thus, further future studies may be conducted by appropriately applying the various co-integration tests, short-run dynamic causal relationship through the vector error correction model and applying different other causality models.